

1 Functional description

The digital output module XI250204 is used to output binary 24 V control signals in a ctrlX I/O station. The terminal has 4 channels in a 2-wire technique. The short-circuit-proof push-pull output switches actively to 24 V or 0 V and has a low output delay. The signals are output DC-synchronously. The signal state is shown at the channel LED on the removable peripheral connector.

The digital outputs are fed via the 24 V supply from U_P .

The logic and peripheral voltage supply as well as the EtherCAT-based module communication are routed through the module.



ⁱ For an application manual of the ctrlX I/O modules, refer to the media directory www.boschrexroth.com/mediadirectory and enter the search term "R911423458".

ⁱ Ensure that the current documentation is consulted. For the current documentations, go to www.boschrexroth.com/mediadirectory and enter the module type as search term.

ⁱ For the integration into the parent system, the respective ESI files are available. For the ESI files, go to <http://www.boschrexroth.com/electrics>, search term "ESI-Files".

2 Ordering data

Type	Part number	Description
XI250204	R911421645	Digital output module 4-channel, DC 24 V, 0.5 A, 2-wire, high-speed, DC-synchronous

ⁱ For more ordering data (accessories), go to the product catalog under www.boschrexroth.com/electrics.

3 Technical data

3.1 General technical data

	XI250204
Number of outputs	4
Connection method	Push-in terminal

	XI250204
Connection technique	2-wire technique
Output current max.	0.5 A per channel The GND contact assigned to the channel may not be loaded with more than the maximum output current of 0.5 A.
Total current of channels	2 A max.
Nominal load	Ohmic, 12 W max. (48 Ω ; at nominal voltage)
Minimum load	10 k Ω
Rising time (T_{Rise})	Without load: 300 ns at 20 k Ω Ohmic nominal load: 330 μ s at 48 Ω , 500 mA
Fall time (T_{FALL})	Without load: 276 ns at 20 k Ω Ohmic nominal load: 30 ns at 48 Ω , 500 mA
Inductive switch-off energy	150 mJ max. per channel
Overload response	Granular channel switch-off with edge steepness limitation and automatic restart; short-circuit-proof in push and pull operation
Feedback voltage resistance	Not resistant to feedback, external measures required
Nominal voltage (U_L/U_P)	DC 24 V (19.2 V to 30 V, including tolerance and residual ripple) PELV/SELV (safety extra-low voltage)
Current consumption U_L	35 mA
Current consumption U_P	15 mA + load
Max. power consumption of the module	1.45 W
Bit width in the process image	1 byte (4 bits used)
Configuration	No address or configuration setting required
Dimensions	12 mm \times 105 mm \times 99 mm (Width \times height \times depth)
Weight	95 g (module including connector)
Electrical isolation	DC 1200 V U_P to U_L , DC 707 V U_P/U_L to FE, tested for 60 s each (not evaluated by UL)
EMC resistance	Acc. to EN 61000-6-2 and EN 61000-6-4
Mounting position	Vertical, on a horizontal mounting rail
Labeling, approvals	CE, UKCA, UL

3.2 Internal schematic diagram

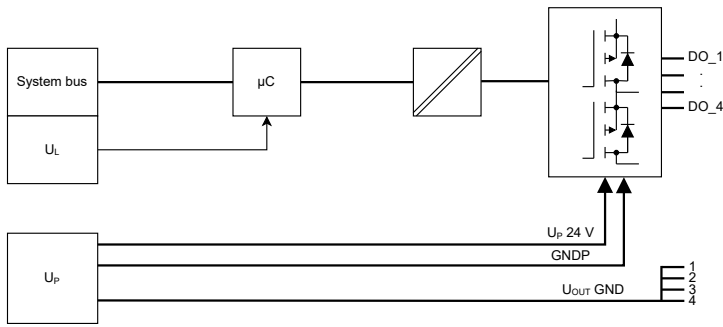

3.3 Ambient conditions

Ambient temperature	
≤ 2,000 m	-25 to +55 °C
2,000 m to 3,000 m	-25 to +50 °C
3,000 m to 4,000 m	-25 to +45 °C
4,000 m to 5,000 m	-25 to +40 °C
Maximum operating altitude Acc. to DIN 60204	5,000 m
Ambient temperature (storage and transport)	-40 to +70 °C
Permitted air humidity according to DIN EN 61131-2 (Operation, storage, transport)	10 to 95 %
Degree of protection Acc. to DIN EN 60 529	IP20 (not evaluated by UL)
Protection class Acc. to DIN EN 61010-2-201	III
Overvoltage category Acc. to IEC 60664-1	2
Contamination level Acc. to EN 61010-1	2, no condensation

NOTICE

Defective device due to contaminated air!

- The ambient air must not contain acids, alkaline solutions, corrosive agents, salts, metal vapors and other electrically conductive contaminants in high concentrations.
- The devices to be installed into the housings and installation compartments must at least comply with the degree of protection IP 54 according to DIN EN 60529.
- The device shall be provided in a suitable fire enclosure in the end-use application.

NOTICE

Defective device due to gases jeopardizing functions

Due to the risk of corrosion, avoid sulphureous gases (e.g. sulphur dioxide (SO₂) and hydrogen sulphide (H₂S)). The device is not resistant against these gases.

NOTICE

Defective device due to overheating

To avoid overheating and to ensure a trouble-free operation of the device, the ambient air has to circulate. Also refer to the section "Installation notes".

3.4 Mechanical tests

Vibration resistance Acc. to DIN EN 60068-2-6	Oscillations, sinusoidal in all three axes, 5 Hz - 8,4 Hz with 3.5 mm amplitude 8.4 Hz -150 Hz with 1 g peak acceleration
Shock test Acc. to DIN EN 60068-2-27	Shock stress: Shock resistance in all three axes

11 ms semi-sinusoidal 15 g

Broadband noise
Acc. to DIN EN 60068-2-64

20-500 Hz with 1.22 g RMS
(Root Mean Square), 30 min in all three axes

For the current approvals, go to
www.boschrexroth.com/electrics.

4 For your safety

4.1 Intended use

Use the module only as specified in the data sheet.

4.2 User qualification

The product use described in this data sheet is only intended for qualified electricians and staff trained by these qualified electricians. The user has to be familiar with the known safety concepts on automation technology, applicable standards and other guidelines.

4.3 Electrical safety

NOTICE

Loss of electric safety

Unintended handling can affect the device safety! Observe the notes in the present data sheet during installation, commissioning and operation.

5 Signal processing

5.1 Synchronizing the application

The application is synchronized in the "DC-synchronous" mode.

The outputs are switched to the global "DC-Sync Output Event".

Example

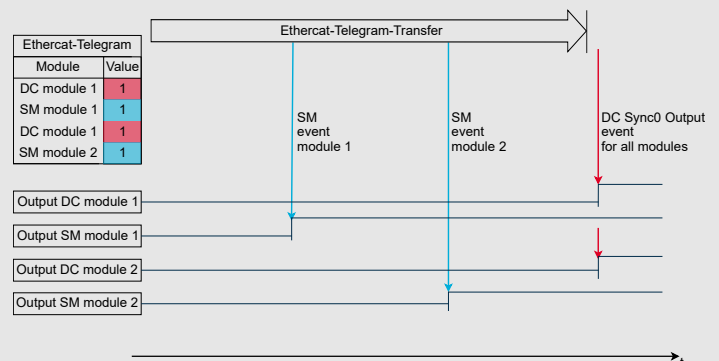

Fig. 1: Temporal response of the outputs for DC- and SM-synchronous modules

In this example, DC- and SM-synchronous output modules are operated in mixed mode (sequence: DC1, SM1, DC2, SM2). Both DC modules are switched to the global "DC Sync0 Output Event". This point in time is usually after the Ethercat telegram has passed the last module.

6 Process data

6.1 Process data of the module

The module is a simple module with a device emulation. Apart from the registers of the EtherCAT slave, no further objects are available for configuration or status.

The following process data is transferred:

Index (hex)	Object name	Type	Access	Description	Default (hex)
7000:01	Out Channel 1.Value	BOOL	RW	Channel 1, output value	0
7010:01	Out Channel 2.Value	BOOL	RW	Channel 2, output value	0
7020:01	Out Channel 3.Value	BOOL	RW	Channel 3, output value	0
7030:01	Out Channel 4.Value	BOOL	RW	Channel 4, output value	0

7 Diagnostic strategy

7.1 Mechanisms

Different mechanisms are used for the diagnostics of the module.

Mechanism	Diagnostics
EtherCAT state machine	EtherCAT system diagnostics
EtherCAT hardware watchdog	
Module status LED	Shows the general module status
Channel status LED	Signals the channel status or the error states

7.2 Module status LED

Device state	LED flashing pattern
Booting	BU BU BU BU BU -- -- -- -- -- ↗
Initialization	BU BU BU BU BU BU BU BU BU BU BU ↗
It is currently configured. Module not yet ready.	GN GN GN GN GN -- -- -- -- -- ↗
Process data transmission, outputs inactive.	GN GN GN GN GN GN GN GN GN GN -- ↗
Module in "Run" state	GN GN GN GN GN GN GN GN GN GN GN ↗
Error and warning states	
Logic or peripheral voltage error	RD RD RD RD RD RD RD RD RD RD RD ↗
Communication or configuration error	RD RD RD RD RD -- -- -- -- -- ↗

ⓘ One square corresponds to a period of 200 ms. The arrow represents the end of a cycle.

- ☐ LED is not on.
- BU LED is blue.
- GN LED is green.
- RD LED is red.

ⓘ A new status is only displayed after the previous flashing cycle has elapsed. A change in status can thus be delayed up to two seconds.

7.3 Channel status LED

Each channel of the module is provided with a channel status LED at the respective signal pin of the plug.

LED	Logic signal state
Off	0
Green	1
Red	Fault: Short circuit or overload

After a short circuit, the edge steepness is limited to protect the module. This limitation lasts for up to two switching edges after the short circuit has been eliminated.

8 Installation

8.1 Clamping point assignment

Clamping point	Assignment	Color
1	1 - DO CH.1	Grey
2	2 - U _O GND	Dark blue
3	3 - DO CH.2	Grey
4	4 - U _O GND	Dark blue
5	5 - DO CH.3	Grey
6	6 - U _O GND	Dark blue
7	7 - DO CH.4	Grey
8	8 - U _O GND	Dark blue

ⓘ

- The channel GND outputs are only to be used as reference potential for the respective output channel.
- These outputs may not be used as peripheral supply GND.
- To supply the connected actuators, use the potential distribution modules, e.g. XI821116.

8.2 Switching off inductive loads

Negative voltages are generated when inductive loads are switched off. If the switch-off energies are greater than specified in the technical data, these switch-off energies can cause damage to the electronics of the module.

NOTICE

Electronic damage due to overload

Use a suitable external freewheeling circuit to protect the module from high voltages when switching off inductive loads.

8.3 Wiring example

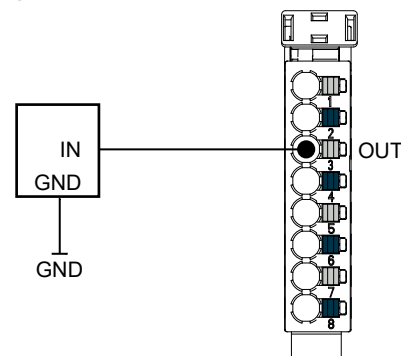

Fig. 2: One-wire actuator

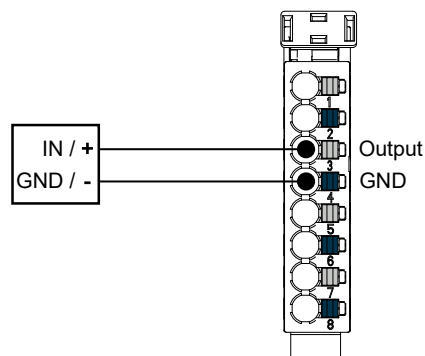

Fig. 3: Two-wire actuator

8.4 Mounting and installation

The application manual for the ctrlX I/O modules contains notes on installation, mounting and dismounting. For the application description, go to:

- ↗ www.boschrexroth.com/MediaDirectory, Search term: ↗ "R911423458" or
- ↗ <https://docs.automation.boschrexroth.com/doc/4126711705/ctrlx-i-o-anwendungsbeschreibung/latest/en/>.

NOTICE

Destruction of the device due to non-compliance with the application manual

Follow the mounting instructions in the application manual to ensure a correct mounting and to prevent damage to the device.

9 License information

9.1 EtherCAT®

EtherCAT®

The ctrlX I/O modules use EtherCAT® technology. "EtherCAT®" is a registered trademark and patented technology licensed by the Beckhoff Automation GmbH, Germany. EtherCAT is an open, internationally standardized standard and developed further by the "EtherCAT Technology Group" (ETG).

