

## 1 Functional description

The analog input terminal XI312204 processes signals in the range from 0 to 10 V in a ctrlX I/O station. The input signal is digitized with a resolution of 16 bits and transferred galvanically isolated to the system level. The 4 input channels are differential inputs. Error states are shown at the channel LED on the removable peripheral connector and routed to the control via the local bus.

The logic and peripheral voltage supply as well as the EtherCAT-based module communication are routed through the module.



Fig. 1: Module XI312204

**i** For a system description of the ctrlX I/O modules, refer to the media directory [↗ www.boschrexroth.com/mediadirectory](http://www.boschrexroth.com/mediadirectory) and enter the search term [↗](http://www.boschrexroth.com/mediadirectory) "R911423458".

**i** Ensure that the current documentation is consulted. For the current documentations, go to [↗ www.boschrexroth.com/mediadirectory](http://www.boschrexroth.com/mediadirectory) and enter the module type as search term.

**i** For the integration into the parent system, the respective ESI files are available. For the ESI files, go to [↗ http://www.boschrexroth.com/electrics](http://www.boschrexroth.com/electrics), search term [↗](http://www.boschrexroth.com/electrics) "ESI-Files".

## 2 Ordering data

Type	Part number	Description
XI312204	R911406105	Analog input module, voltage between 0 and 10 V

**i** For more ordering data (accessories), go to the product catalog under [↗ www.boschrexroth.com/electrics](http://www.boschrexroth.com/electrics).

## 3 Technical data

### 3.1 General technical data

XI312204	
Number of inputs	4
Connection method	Push-in terminal
Connection technique	2-wire, shielded, twisted in pairs
Signal type	Differential
Input signal	0 V to 10 V
Input resistance	>250 kΩ
Cutoff frequency of input filter	12.8 kHz
Conversion time	100 μs
Resolution D/A	16 bits incl. sign
Accuracy	Typ. ± 0.1 % of the end value of the measured range (MBE) Max. ± 0.3% of MBE
Overload protection	No, DC 30 V max.
Common Mode	Max. ±35 V compared to U <sub>P</sub> GND
Voltage supply	U <sub>P</sub> via jumper contacts
Nominal voltage (U <sub>L</sub> / U <sub>P</sub> )	DC 24 V (19.2 V to 30 V, including tolerance and residual ripple) PELV/SELV (safety extra-low voltage)
Current consumption U <sub>L</sub>	40 mA
Current consumption U <sub>P</sub>	20 mA
Max. power consumption of the module	1.5 W
Bit width, input data in the process data image (including filling bits)	18 bytes in the "standard" representation 12 bytes in the "compact" representation (can be set channel-granularly)
Parameterization	Via ctrlX Works (start parameter)
Configuration	No address or configuration setting required
Dimensions	12 mm × 105 mm × 99 mm (width × height × depth)
Weight	95 g (module including connector)
Electrical isolation	DC 1211 V U <sub>P</sub> to U <sub>L</sub> , DC 707 V U <sub>P</sub> /U <sub>L</sub> to FE (not evaluated by UL)
EMC resistance	Acc. to EN 61000-6-2 and EN 61000-6-4
Mounting position	Vertical, on a horizontal support rail
Labeling, approvals	CE, UKCA UL (↗ File No. E210730)

## 3.2 Internal schematic diagram

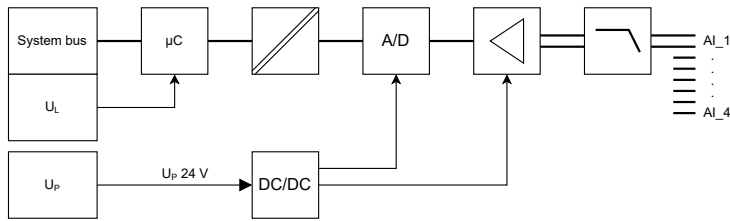

Fig. 2: Internal schematic diagram

## 3.3 Ambient conditions

Ambient temperature	
Up to 2000 m	-25 to +45 °C
From 2000 m	-25 to +40 °C
Maximum operating altitude	3000 m
Acc. to 60204	
Ambient temperature (storage and transport)	
	-40 to +70 °C
Permitted air humidity according to DIN EN 61131-2	
Operation	5 to 95 %
Storage	10 to 95 %
Transport	45 to 95 %
Degree of protection	
Acc. to DIN EN 60 529	IP20 (not evaluated by UL)
Protection class	
Acc. to DIN EN 61010-2-201	III
Overvoltage category	
Acc. to IEC 60664-1	2
Contamination level	
Acc. to IEC 61010-1	2, no condensation

### NOTICE

#### Defective device due to contaminated air!

- The ambient air must not contain acids, alkaline solutions, corrosive agents, salts, metal vapors and other electrically conductive contaminants in high concentrations.
- The devices to be installed into the housings and installation compartments must at least comply with the degree of protection IP 54 according to DIN EN 60529.
- The device shall be provided in a suitable fire enclosure in the end-use application.

### NOTICE

#### Defective device due to gases jeopardizing functions

Due to the risk of corrosion, avoid sulphureous gases (e.g. sulphur dioxide (SO<sub>2</sub>) and hydrogen sulphide (H<sub>2</sub>S)). The device is not resistant against these gases.

### NOTICE

#### Defective device due to overheating

To avoid overheating and to ensure a trouble-free operation of the device, the ambient air has to circulate. Also refer to the section "Installation notes".

## 3.4 Mechanical tests

Vibration resistance	
Acc. to DIN EN 60068-2-6	Oscillations, sinusoidal in all three axes, 5 Hz - 8,4 Hz with 3.5 mm amplitude 8.4 Hz -150 Hz with 1 g peak acceleration
Shock test	
Acc. to DIN EN 60068-2-27	Shock stress: Shock resistance in all three axes 11 ms semi-sinusoidal 15 g
Broadband noise	
Acc. to DIN EN 60068-2-64	20-500 Hz with 1.22 g RMS (Root Mean Square), 30 min in all three axes

For the current approvals, go to [www.boschrexroth.com/electrics](http://www.boschrexroth.com/electrics).

## 4 For your safety

### 4.1 Intended use

Only use the module as specified in the data sheet.

### 4.2 User qualification

The product use described in this data sheet is only intended for qualified electricians and staff trained by these qualified electricians. The user has to be familiar with the known safety concepts on automation technology, applicable standards and other guidelines.

### 4.3 Electric safety

#### NOTICE

#### Loss of electric safety

Unintended handling can affect the device safety! Observe the notes in the present data sheet during installation, commissioning and operation.

## 5 Signal processing

### 5.1 General information on signal processing

The signal processing of the module consists of several steps shown in this section. Parts like the low-pass filter and the oversampling are implemented in hardware components while other steps are implemented as firmware functions.

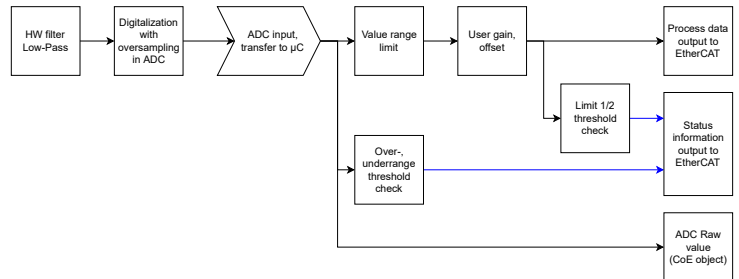

Fig. 3: Overview on signal processing

To disable channels, see Chapter 7.2 "Disabling channels" on page 5. No diagnostic messages are transmitted for disabled channels.

### 5.2 Distinctive values and data format

Input signal	Process data value	Percent, measuring range	Notes
Voltage in V	Voltage in mV		
10.8	10800	108%	Message, upper range limit
10.7	10700	107%	Reset message, upper range limit
10	10000	100%	
0	0	0%	Value limitation down to 0 V
-0.05	0		Reset message, lower range limit
-0.15	0		Message, lower range limit

Process data is transferred in the "signed int 16" format. Its values are normalized to mV. The process data corresponds directly to the values read in at the input. It depends on the gain and offset calculation. Thus, the conversion to an abstract value range is omitted. The value can be directly used as voltage value in the application.

Note that the input value range of the module from 0 V up to reaching the upper limit value is specified at 108% of the end value of the measured range (MBE). Normally, higher values

are read in and transmitted, but the upper limit of the technically reachable value range depends on the tolerances and can change in future hardware releases.

Values smaller than 0 V are not transmitted.

One bit at the ADC corresponds to the value 0.335 mV.

### 5.3 Synchronizing the application

The application is synchronized in the "SM synchronous" mode.

### 5.4 "Filter" and "Oversampling"

A first order hardware low-pass filter limits the frequency range at the input of the analog digital converter (ADC). The filtered signal is present at the analog digital converter.

Depending on the setting of the value "Oversampling factor" in the object "Device settings" F800:01(hex), the Oversampling of the ADC can be set. If Oversampling is switched on, the ADC samples multiple values and transmits the average of the measured values. An Oversampling-Ratio of 0 disables the Oversampling. 2 means that two Samples can be read in per transferred process data for example. Thus, the effective useful signal frequency can be restricted.

### 5.5 Limit value check of the upper and lower range limit

The ADC input data is used to check whether the values are above or below the valid range. The status bits "Overrange" and "Underrange" or "Wire break" are set accordingly in the process data. There are different values at which the diagnostics is set and reset.

For the limits, go to the chapter "Distinctive values and data formats".

### 5.6 User Scale: Gain and offset adjustment

The "User Scale" functionality allows an individual correction of the gain (User Gain) and the offset (User Offset) for each channel.

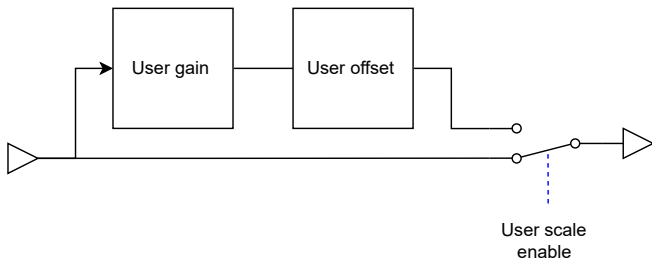

Fig. 4: User Gain and Offset

Enable the functionality "User Scale" to apply the correction. Therefore, set the parameter 80x0:05(hex) "User scale enable" to 1.

Output values to calculate gain and offset:

Value_Range:	The value range at the input of the "User Scale" calculation
Scaled_Value_Range:	The desired value range at the output of the User Scale calculation
Lower_Range_End_Value:	The value at the lower end of the input value range
Scaled_Lower_Range_End_Value:	The desired value at the lower end of the output value range

The values for gain and offset are calculated as follows:

Gain_Factor	= Scaled_Value_Range ÷ Value_Range
User_gain	= (Gain_Factor × 10000) – 10000

Enter the value "User\_gain" into the parameter 80x0:01(hex) "User gain".

Offset	= (Scaled_Lower_Range_End_Value) – (Lower_Range_End_Value × Gain_Factor)
User_offset	= Offset × 1000

Enter the value "User\_offset" into the parameter 80x0:02(hex) "User offset".

⚠ Note that possible limitations of the value range also remain after the "User Scale" calculation. For more detailed information, refer to the chapter "Distinctive values and data format".

⚠ Offset and gain settings can only be made in the "Pre-OP" state. Set the settings via "Start parameters" to ensure that the start parameters are automatically written to the module each time the EtherCAT bus starts.

#### Example 1:

Module is XI422204, analog output with ±10 V. The target is to reduce the value range to values between -3V and +8V while the values of the application still use the value range from -10 V to +10 V.

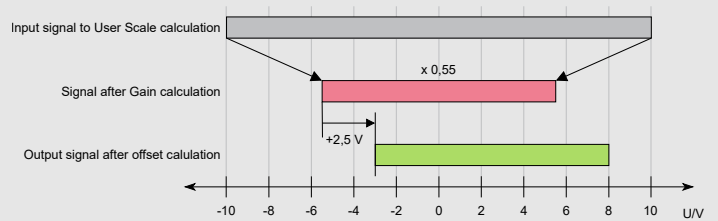

Fig. 5: Value range offset from -10 V .. +10 V to -3 V .. +8 V

Value_Range	= 10 V – (-10 V) = 20 V
Scaled_Value_Range	= 8 V – (-3 V) = 11 V
Lower_Range_End_Value	= -10 V
Scaled_Lower_Range_End_Value	= -3 V
Gain_Factor	= 11 V ÷ 20 V = 0.55
User_gain	= (0.55 × 10000) – 10000 = -4500
Offset	= (-3 V) – (-10 V × 0.55) = 2.5 V
User_offset	= 2.5 × 1000 = 2500

#### Example 2

Module is XI342204, analog input from 4 to 20 mA. The connected system specifies 4.5 mA as minimum value and 18.5 mA as maximum value. The values should be mapped to a value range from 4 to 20 mA.

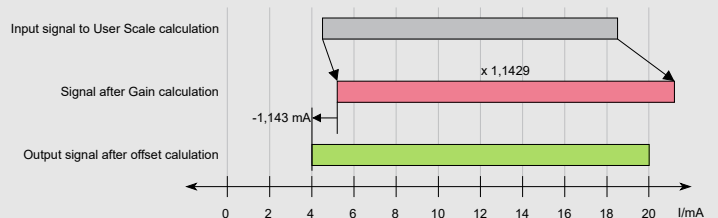

Fig. 6: Value range offset from the range 4.5 mA to 18.5 mA to the range 4 mA to 20 mA

Value_Range	= 18.5 mA – 4.5 mA = 14 mA
Scaled_Value_Range	= 20 mA – 4 mA = 16 mA
Lower_Range_End_Value	= 4.5 mA
Scaled_Lower_Range_End_Value	= 4 mA
Gain_Factor	= 16 mA ÷ 14 mA = 1.1429
User_gain	= (1.1429 × 10000) – 10000 = 1429
Offset	= 4 mA – (4.5 mA × 1.1429) = -1.143
User_offset	= -1.143 × 1000 = -1143

### 5.7 Limit value check of the process data

There are two individual and independent limit value checks per channel specifying whether the process data value is lower, equal to or higher than the limit value set.

The limit value to be checked is set in the parameter "Limit 1" or in the parameter "Limit 2" of the object "Channel x settings". The format of the limit value corresponds to that of the process data.

Each individual limit check is enabled using the parameter "Limit y enable" in the object "Channel x settings".

The result of the check is output in the process data "Ch. x Limit y". Alternatively, it can be retrieved either via the CoE object 60x0:04(hex) ("Channel x Limit 1") or the CoE object 60x0:06(hex) ("Channel x Limit 2"). Meaning of the bits:

Bit	Meaning
0	1 if the value is lower than or equal to the set date.
1	1 if the value is higher than or equal to the set date.

## 6 Object directory

### 6.1 CoE standard objects

The object directory of the module contains objects that can be triggered via SDO services. These are defined in the ETG standards:

Index (hex)	Name
1000	Device type
1001	Error register
1008	Device name
1009	Hardware version
100A	Software version
1018	Identify
10F1	Error settings
10F3	Diagnosis history
10F8	Timestamp object
1Ann	PDO mapping TxPDO
1C00	Sync manager type
1C12	Sync manager 2 assignment
1C13	Sync manager 3 assignment
1C33	SM input parameter
F000	Modular device profile
F100	Device state

### 6.2 Module-specific CoE objects

Objects with a module-specific design are described in the following table.

Index (hex)	Object name	Data type	Direction	Error, warning, information	Diagnostic number, description	Unit
<b>6000</b>	<b>Channel 1, 2, 3, 4</b>					
<b>6010</b>						
<b>6020</b>						
<b>6030</b>						
60x0:01	Value	Int16	IN	–	–	mV
60x0:02	Underrange	Bit	IN	W	2360(hex)	–
60x0:03	Ovrrange	Bit	IN	W	8910(hex)	–
60x0:04	Limit 1	2Bit	IN	–	Bit0: Value ≤ Limit 1 Bit1: Value ≥ Limit 1	–
60x0:06	Limit 2	2Bit	IN	–	Bit0: Value ≤ Limit 2 Bit1: Value ≥ Limit 2	–
A000:0	Material number	String(20)	IN	–	–	–
A010:0	Full serial number	String(20)	IN	–	–	–
F100:01	Periphery voltage ok	Bit	IN	I	3400(hex)	–
F100:02	Error	Bit	IN	E	1000(hex)	–

### 6.3 CoE objects for parameterization

The module can be parameterized using these objects. Each channel can be freely parameterized. The initial value for the objects is either "0" or "false".

⚠ The module does not remanently save the parameter values. To automatically load the settings required upon each bus start, set the values in the start parameters of the Engineering.

Index (hex)	Object name	Data type	Access	Unit	Description
<b>8000</b>	<b>Channel 1, 2, 3, 4 settings</b>				
<b>8010</b>					
<b>8020</b>					
<b>8030</b>					
80x0:01	User gain	Int32	RW	–	–
80x0:02	User offset	Int16	RW	–	–
80x0:03	Limit 1	Int16	RW	mV	–
80x0:04	Limit 2	Int16	RW	mV	–
80x0:05	User scale enable	Bit	RW	–	Enabling the User Scale calculation
80x0:06	Limit 1 enable	Bit	RW	–	Enabling the limit value check "Limit 1"
80x0:07	Limit 2 enable	Bit	RW	–	Enabling the limit value check "Limit 2"
80xE:01	ADC Raw value	Int16	RO	–	–
<b>F800</b>	<b>Device Settings</b>				
F800:01	Oversampling factor	3Bit	RW	–	Oversampling Rate (0, 2, 4, 8, 16, 32, 64)

## 7 Process data

### 7.1 Process data of the module

The module is provided with data that is implemented into the cyclic process data image. Depending on the setting "Standard" or "Compact", the module is represented as shown in the following tables.

Diagnostic information can also be retrieved via acyclic services using CoE. They are shown there as index 80x0(hex) (see Chapter 6.2 "Module-specific CoE objects" on page 4). The current values as well as the diagnostic data can be shown and hidden in the Engineering. This allows the reduction of the amount of data in the application.

Process data consists of the value and the diagnostic data in the "Standard" representation:

Word 1	INT	IN	Channel 1 Value
Word 2		IN	
	Byte 1	IN	
	Bit 0	IN	Channel 1 Wire break
	Bit 1	IN	Channel 1 Overrange
	Bit 2-3	IN	Channel 1 Limit 1
	Bit 4-5	IN	Channel 1 Limit 2
Word 3	INT	IN	Channel 2 Value
Word 4		IN	
	Byte 1	IN	
	Bit 0	IN	Channel 2 Wire break
	Bit 1	IN	Channel 2 Overrange
	Bit 2-3	IN	Channel 2 Limit 1
	Bit 4-5	IN	Channel 2 Limit 2
Word 5	INT	IN	Channel 3 Value
Word 6		IN	
	Byte 1	IN	
	Bit 0	IN	Channel 3 Wire break
	Bit 1	IN	Channel 3 Overrange
	Bit 2-3	IN	Channel 3 Limit 1
	Bit 4-5	IN	Channel 3 Limit 2
Word 7	INT	IN	Channel 4 Value
Word 8		IN	
	Byte 1	IN	
	Bit 0	IN	Channel 4 Wire break
	Bit 1	IN	Channel 4 Overrange
	Bit 2-3	IN	Channel 4 Limit 1
	Bit 4-5	IN	Channel 4 Limit 2
Word 9		IN	
	Byte 1	IN	
	Bit 0	IN	Periphery voltage ok
	Bit 1	IN	Error

Table 1: Standard figure

To directly arrange the status bits one after another and thus to reduce the amount of filling bites, select "Channel x compact" as well as "Device state compact" in the Engineering.

Process data consists of the input value and the diagnostic data in the "Compact" representation:

Word 1	INT	IN	Channel 1 Value
Word 2	INT	IN	Channel 2 Value
Word 3	INT	IN	Channel 3 Value
Word 4	INT	IN	Channel 4 Value
Word 5		IN	
	Byte 1	IN	
	Bit 0	IN	Periphery voltage ok
	Bit 1	IN	Error
	Bit 2	IN	Channel 1 Wire break
	Bit 3	IN	Channel 1 Overrange
	Bit 4-5	IN	Channel 1 Limit 1
	Bit 6-7	IN	Channel 1 Limit 2
	Byte 2	IN	
	Bit 2	IN	Channel 2 Wire break
	Bit 3	IN	Channel 2 Overrange
	Bit 4-5	IN	Channel 2 Limit 1
	Bit 6-7	IN	Channel 2 Limit 2
Word 6		IN	
	Byte 1	IN	
	Bit 2	IN	Channel 3 Wire break
	Bit 3	IN	Channel 3 Overrange
	Bit 4-5	IN	Channel 3 Limit 1
	Bit 6-7	IN	Channel 3 Limit 2
	Byte 2	IN	
	Bit 2	IN	Channel 4 Wire break
	Bit 3	IN	Channel 4 Overrange
	Bit 4-5	IN	Channel 4 Limit 1
	Bit 6-7	IN	Channel 4 Limit 2

Table 2: "Compact" figure

## 7.2 Disabling channels

Do not disable unused channels in the process data image. This reduces the data width in the process data image. Disabled channels are also disabled in the signal processing. No diagnostic messages are generated for these channels and the error bits in the respective CoE object no longer contain any valid information.

To disable a channel, edit the process data mapping (PDO assignment) of the module in the I/O Engineering Tool. The mapping can be set separately for input and output data. Disable process data of the channel. If the channel has its own Control/Status object in the input/output data, disable it as well.

# 8 Diagnostic strategy

## 8.1 Mechanisms

Different mechanisms are used for the diagnostics of the module.

Mechanism	Diagnostics
EtherCAT state machine	EtherCAT system diagnostics
EtherCAT hardware watchdog	
Diagnostic objects in the CoE object directory	Extended diagnostics, e.g. peripheral errors
10F1(hex)	Error settings
Diagnosis history object	20 diagnostic messages can be stored
10F3(hex)	Diagnosis history
Module status LED	Shows the general module status
Channel status LED	Signals the channel status or the error states

## 8.2 Diagnosis history

The object 10F3(hex) is implemented as ring memory into the "Overwrite mode". The latest 20 diagnostic messages are stored. Older messages are deleted.

The following table shows the structure of the Diagnosis History object.

Index (hex)	Sub-index	Object name	Data type	Rights	Meaning
10F3		Diagnosis history			Diagnostic statistics
	01	Maximum messages	UINT8	R	Maximum number of messages
	02	Newest message	UINT8	R	Latest message
	03	Newest acknowledged message	UINT8	R/W	Latest confirmed message. Writing "0" deletes the messages in the ring memory.
	04	New messages available	Boolean	R	New message available
	05	Flags	UINT16	R/W	Setting of the object response. Refer to ETG.1020
	06 - 26	Diagnosis message	String	R	Diagnostic message according to ETG.1020

## 8.3 Status codes

EtherCAT transfers diagnostic messages via the "Diagnostic History" functionality.

Error, warning, information	Text ID (hex)	Text
E	1000	Module error (internal error, temperature, sum error bit is set)
W	2360	Open circuit (wire break) at channel x (channel number is transferred)
I	3400	Peripheral supply voltage ( $U_P$ ) missing
W	8910	Overrange at channel
W	8920	Underrange at channel

The diagnostics "Wire break" is run channel-granularly.

⚠ No diagnostic messages are transmitted for disabled channels. To disable channels, see ↗ Chapter 7.2 "Disabling channels" on page 5.

If an error is not present anymore, a respective "Info" message was sent with identical text and note "[OK]".

## 8.4 Module status LED

Device state	LED flashing pattern
Booting	
Initialization	
It is currently configured. Module not yet ready.	
Process data transmission, outputs inactive.	
Module in "Run" state	
<b>Error and warning states</b>	
Logic or peripheral voltage error	
Communication or configuration error	

⚠ One square corresponds to a period of 200 ms. The arrow represents the end of a cycle.

- --: LED is not on.
- BU: LED is blue.
- GN: LED is green.
- RD: LED is red.

⚠ A new status is only displayed after the previous flashing cycle has elapsed. A change in status can thus be delayed up to two seconds.

## 8.5 Channel status LED

Each input channel of the module is provided with a channel status LED at the plug. Refer to ↗ Chapter 9.1 "Clamping point assignment" on page 6.

Meaning of the channel LED:

LED	Meaning
Red	Signal error: Overrange, underrange or wire break
Off	No signal error

⚠ No diagnostics is generated for disabled channels, the LED always remains off. To disable channels, see ↗ Chapter 7.2 "Disabling channels" on page 5.

## 9 Installation

### 9.1 Clamping point assignment

Clamping point	Signal	LED	Pusher
1	AI Kanal 1+	Red	Grey
2	AI Kanal 1-	None	Grey
3	AI Kanal 2+	Red	Grey
4	AI Kanal 2-	None	Grey
5	AI Kanal 3+	Red	Grey
6	AI Kanal 3-	None	Grey
7	AI Kanal 4+	Red	Grey
8	AI Kanal 4-	None	Grey

### 9.2 Connection instructions

#### 9.2.1 Differential input and potential reference

For analog inputs, there are differential inputs without a reference to an external mass. Thus, note that the "Common Mode" - the average value of the signals at the plus and minus input - is not higher compared to the internal mass  $U_P$  GND than the values specified in the technical data.

For the single-ended connection of 2- or 3-conductor sensors, connect the minus input with  $U_P$  GND.

#### 9.2.2 Cable and shielding

##### NOTICE

##### Electronic damages and measuring errors

Unshielded cables can cause that tolerance limits are easily exceeded in an environment prone to interferences.

Always connect the components with shielded cables twisted in pairs.

Connect the cable shielding to the functional earth immediately after entering the control cabinet. Route the cable with its shielding up to the module. The signal cables should be routed the shortest possible without shielding.

For the best connection directly in front of the module, the shield connection set (R911173030) is provided together with the busbar (R911173283).

## 9.3 Connection examples

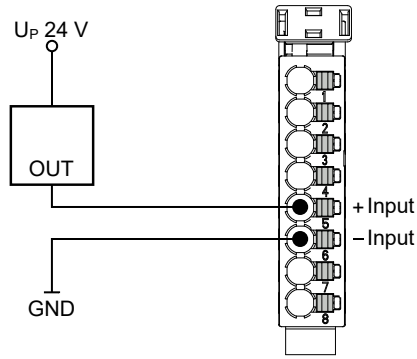

Fig. 7: 2-wire sensor  
Connect "- Input" of the module to GND.

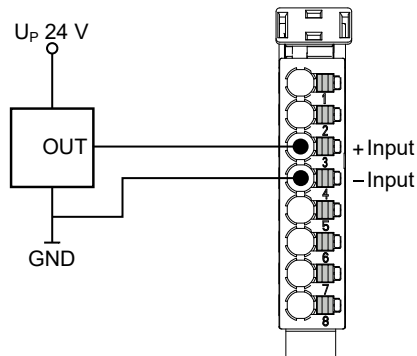

Fig. 8: 3-wire sensor  
Connect "- Input" of the module to the sensor GND.

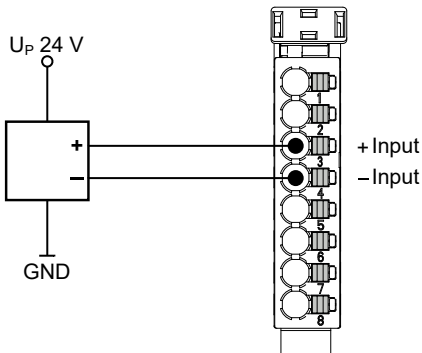

Fig. 9: 4-wire sensor

It is recommended to use the same supply for the voltage supply of the sensor as for  $U_P$  of the module. The connection via the potential distribution terminals XI821116, XI822116 or XI824116 is the recommended connection.

## 9.4 Installation notes

### NOTICE

#### Device destruction due to electrostatic discharge

The device contains components that can be damaged or destroyed by electrostatic discharge. Comply with the required safety measures against electrostatic discharge (ESD) acc. to EN 61340-5-1 when operating the module.

- Mounting location  
The module has the degree of protection IP 20 and is thus intended for use in a closed control cabinet or control box (terminal box) with the degree of protection IP 54 or higher. The control cabinet fulfills the function of the final safety enclosure. The modules must be installed in the final safety enclosure. They have to be provided with sufficient rigidity according to UL 61010-1, 61010-2-201 and have to meet the requirements with regard to fire propagation.
- End clamps  
Fasten end clamps of the type SUP-M01-ENDHALTER (R911170685) on both sides of the station. End clamps ensure the correct fastening on the support rail and are

used as lateral end elements. Always fasten one end clamp of the station before mounting the station. This ensures the following:

- It impedes the shifting of the modules
- The installation place for the end clamps is secured.
- Support rail  
Mount the module on a 35 mm standard support rail. Only use a support rail TH 35-7.5 acc. to EN 60715. The fastening distance of the support rails may not exceed 200 mm. This distance is required to ensure stability while mounting and dismantling the module.

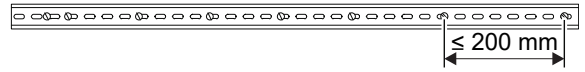

- Provide the following minimum distances for sufficient cooling:

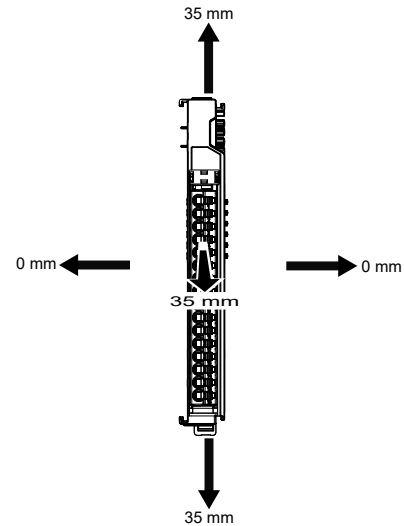

Fig. 10: Ventilation distance

- Additionally, provide sufficient distance for mounting, dismantling, plugs and cables.
- If more devices are connected in series to the station on the left or right, the surface temperature may not exceed 60° C
- In case of a several line design, the supply air has to be measured under each line and its limit value may not be exceeded. For the permitted ambient temperatures, refer to the chapter "Ambient conditions".

## 9.5 Mounting the ctrlX I/O module

### NOTICE

#### Damage of the device by plug mounting under voltage!

Disconnect the module and all connected module components from voltage before mounting or dismantling.

### NOTICE

#### Damage of the device by short circuit of patch connectors

There is an endcover on the right upon delivery of the bus coupler. Remove this endcover to connect the modules at the bus coupler in series. Position the endcover on the last module of the station to protect it against short circuit and contamination.

### NOTICE

#### Possible damage to property due to unintended mounting of the support rail

- Connect the support rail to a functional earth.
- Mount the module on a support rail.
- Install the module in a control cabinet or in an appropriate housing.

**NOTICE**

**Module is not fixed correctly due to open support arm mounting!**

Before mounting, ensure that the support arm mounting of the control is not in open position. If required, release the clamping of the open position using the locking lever, refer to the following figure 11.

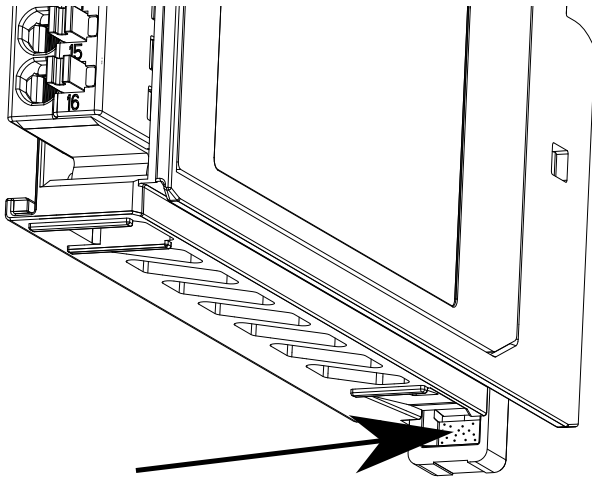

Fig. 11: Locking lever to release the clamping of the open position.

Each module has to be snapped separately.

**9.6 Positioning plugs**

1. Position the plug on the connector holder, see ①.
2. The plug engages at the locking lever, see ②

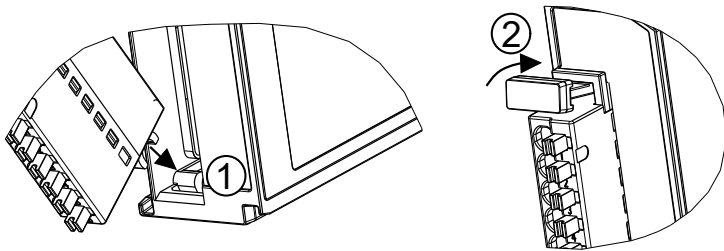

Fig. 12: Positioning plug

**9.7 Notes on the electrical connection**

- To avoid EMC interferences due to loop formation, 24 V voltage potential and ground (GND) have to be connected in star shape from the 24 V power supply unit to the connections for logic voltage (U<sub>L</sub>) and peripheral voltage (U<sub>P</sub>). Twin wire end ferrules to loop the potentials are thus not required.
- Use only insulated copper wires suitable for at least 75 °C.

**9.7.1 The plug and its functions**

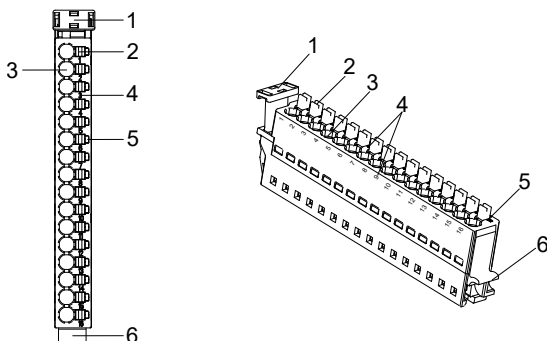

Fig. 13: Plug overview

- ① Locking lever
- ② Pusher
- ③ Clamping point
- ④ Clamping point labeling

- ⑤ Status display
- ⑥ Rotation axis

**9.7.2 Tools**

- Use the "Phoenix Crimpfox 6" crimping plier to crimp wire end ferrules. The ordering number is: "1212034 Crimpfox 6" at Phoenix Contact.
- Use a slotted screwdriver with a 2.5 mm blade.

**9.7.3 Permitted strands**

- Solid core  
Stripping length: 8.5 mm ±.5 mm, burr-free
- Braid without wire end ferrule  
Stripping length: The length of the stripped and 360° twisted braid has to be 8.5 mm ±0.5 mm
- Braid with wire end ferrule
- Use a cable cross-section corresponding to the current (minimum 0.2 mm<sup>2</sup>, maximum 1.5 mm<sup>2</sup>) to avoid an excessive increase in temperature. A cable cross-section of 1.5 mm<sup>2</sup> is specified for the power supply (U<sub>P</sub>) of 8 A. The minimum cable cross-section for the power supply (U<sub>L</sub>) is 0.75 mm<sup>2</sup>.
- The insulation of the cables used has to correspond to the rated voltage.

**9.7.4 Wire end ferrules**

- Wire end ferrules with and without insulating collar are permitted with a contact length of 8 mm according to DIN 46228.
- Maximum dimensions of the crimped wire end ferrule:  
Height 1.45 mm  
Width 2.34 mm
- Twin wire end ferrules are not permitted in the ctrlX I/O system.

**9.7.5 Orientation of the wire end ferrules**

- The orientation of the wire end ferrule in the clamping point has to be vertical.

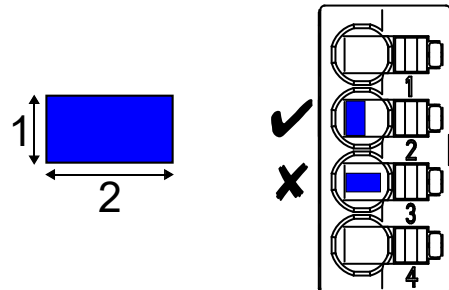

Fig. 14: Orientation of the wire end ferrules in the clamping point

- 1 Height of the crimped wire end ferrule
- 2 Width of the crimped wire end ferrule

**9.7.6 Mounting strands**

- Press the pusher with a suitable slotted screwdriver.
- Insert the strand into the terminal point as far as possible.
- Release the pusher.

**9.7.7 Unmounting strands**

- Press the pusher with a suitable slotted screwdriver.
- Remove strands.
- Release the pusher.

**9.7.8 Mounting notes for UL certification**

**Permitted strands**

- Use a braid with wire end ferrules for UL devices.
- The following wire end ferrules are permitted:
  - Wire end ferrules with insulating collar as per the table:

Cable cross-section in AWG	Cable cross-section mm <sup>2</sup>	Ordering numbers of the wire end ferrules (Weidmüller company)
24 AWG	0.2 mm <sup>2</sup>	9025760000, 500 pieces
22 AWG	0.35 mm <sup>2</sup>	9025770000, 500 pieces
20 AWG	0.5 mm <sup>2</sup>	0690700000, 500 pieces 1476230000, 100 pieces
18 AWG	0.75 mm <sup>2</sup>	0462900000, 500 pieces 1476240000, 100 pieces
-	1 mm <sup>2</sup>	0463000000, 500 pieces 1476250000, 100 pieces
16 AWG	1.5 mm <sup>2</sup>	0463100000, 500 pieces 1476270000, 100 pieces

### Strand orientation

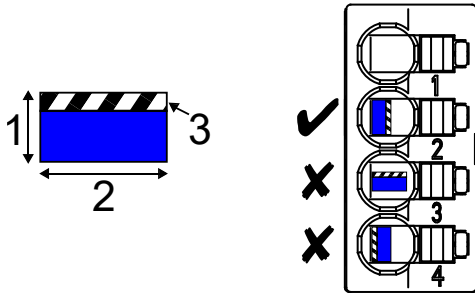

Fig. 15: Orientation of the wire end ferrules in the clamping point

- 1 Height of the crimped wire end ferrule
- 2 Width of the crimped wire end ferrule
- 3 Crimped side of the wire end ferrule

## 9.8 Removing plug

1. Press the locking lever of the plug at the top, see ①
2. Remove the plug, see ②.

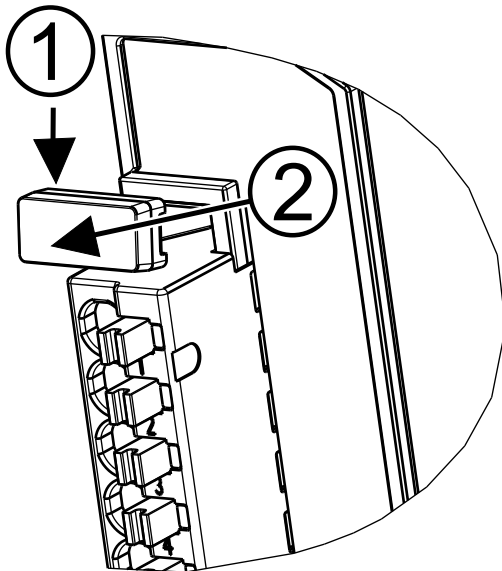

Fig. 16: Removing plug

## 9.9 Dismounting module

⚠ For dismounting, use a common tool such as a slotted screwdriver with a 2.5 mm blade.

### NOTICE

#### Destruction of components and devices due to mounting and dismounting under voltage!

Disconnect the module and all connected module components from voltage before mounting or dismounting.

## Removing module from support rail

1. Use a suitable tool (e.g. slotted screwdriver) and put it into the lower disengaging mechanism (base latch) of the module and disengage the module (see (A) in the following figure). The base latch is locked in the open position.
2. Remove the module vertically to the support rail [see (B) in the following figure].

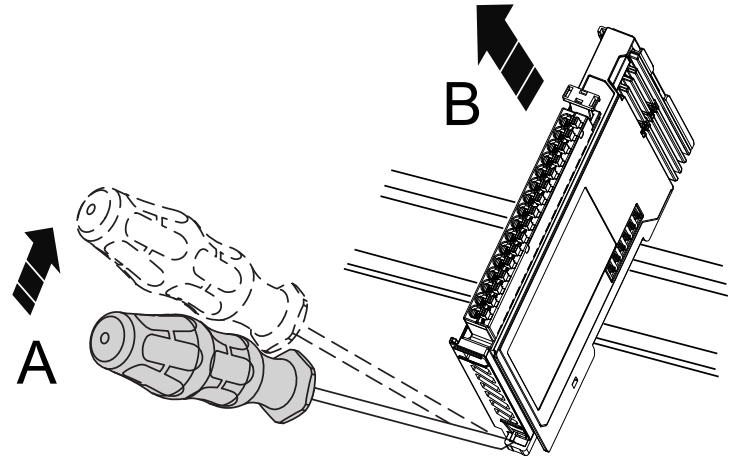

Fig. 17: Removing module from support rail

⚠ Before mounting the module on the support rail again, release the clamping of the open position again. Press the locking lever, refer to the figure 11.

# 10 Firmware update via FoE

### ⚠ WARNING

#### Risk of injury due to unsafe machine states

The machine has to be in a safe state before updating.

The firmware of the module can be updated via FoE. For new firmware files, go to [www.boschrexroth.com/mediadirectory](http://www.boschrexroth.com/mediadirectory) and search for the type code of the module.

The firmware module can be updated with all EtherCAT masters supporting the file download via FoE. The module has to be in the BOOTSTRAP state. Entering a password or a file name is not required.

If the update has been completed successfully, the module is restarted as soon as the module state changes from BOOTSTRAP to another state. The reloaded firmware is started.

⚠ Do not disconnect the voltage supply of the module during the file transfer.

Please note that the logic voltage supply is temporarily interrupted for the following modules when completing the firmware update of the bus coupler and a subsequent restart.

⚠ If switching to INIT is not possible, disconnect the ctrlX I/O from the power supply and connect it again.

⚠ The new firmware version might require an updated description file in the Engineering to use new functions. For details, refer to the release notes.

Check whether the latest version of the description file is installed.

## 10.1 ctrlX I/O Engineering

Within ctrlX I/O Engineering, the required user interface is only displayed for modules supporting a firmware update.

1. First change to the active state in ctrlX I/O Engineering by enabling "Show online data". This is the requirement to update the firmware. The corresponding user interface tab is only displayed if the requirement is met.
2. To open the device editor, double-click on the module in the ctrlX I/O Engineering device tree and select the "FoE" tab.
3. In the "Download" section, select the firmware file (\*.EFW) under "Local file name". Ensure that this is the correct file for the module to be updated.
4. Check that the option "Required state" is active under "Details" and that BOOTSTRAP is selected.

5. Use the "Download" button to start the firmware update.

## 11 License information

### 11.1 EtherCAT®



The ctrlX I/O modules use EtherCAT® technology. "EtherCAT®" is a registered trademark and patented technology licensed by the Beckhoff Automation GmbH, Germany. EtherCAT is an open, internationally standardized standard and developed further by the "EtherCAT Technology Group" (ETG).

### 11.2 Libhydrogen

ISC License

Copyright (c) 2017-2019, Frank Denis

Permission to use, copy, modify, and/or distribute this software for any purpose with or without fee is hereby granted, provided that the above copyright notice and this permission notice appear in all copies.

THE SOFTWARE IS PROVIDED "AS IS" AND THE AUTHOR DISCLAIMS ALL WARRANTIES WITH REGARD TO THIS SOFTWARE INCLUDING ALL IMPLIED WARRANTIES OF MERCHANTABILITY AND FITNESS. IN NO EVENT SHALL THE AUTHOR BE LIABLE FOR ANY SPECIAL, DIRECT, INDIRECT, OR CONSEQUENTIAL DAMAGES OR ANY DAMAGES WHATSOEVER RESULTING FROM LOSS OF USE, DATA OR PROFITS, WHETHER IN AN ACTION OF CONTRACT, NEGLIGENCE OR OTHER TORTIOUS ACTION, ARISING OUT OF OR IN CONNECTION WITH THE USE OR PERFORMANCE OF THIS SOFTWARE.

### 11.3 Ring-buffer

The MIT License (MIT)

Copyright (c) 2014, Anders Kalør

Permission is hereby granted, free of charge, to any person obtaining a copy of this software and associated documentation files (the "Software"), to deal in the Software without restriction, including without limitation the rights to use, copy, modify, merge, publish, distribute, sublicense, and/or sell copies of the Software, and to permit persons to whom the Software is furnished to do so, subject to the following conditions: The above copyright notice and this permission notice shall be included in all copies or substantial portions of the Software.

THE SOFTWARE IS PROVIDED "AS IS", WITHOUT WARRANTY OF ANY KIND, EXPRESS OR IMPLIED, INCLUDING BUT NOT LIMITED TO THE WARRANTIES OF MERCHANTABILITY, FITNESS FOR A PARTICULAR PURPOSE AND NONINFRINGEMENT. IN NO EVENT SHALL THE AUTHORS OR COPYRIGHT HOLDERS BE LIABLE FOR ANY CLAIM, DAMAGES OR OTHER LIABILITY, WHETHER IN AN ACTION OF CONTRACT, TORT OR OTHERWISE, ARISING FROM, OUT OF OR IN CONNECTION WITH THE SOFTWARE OR THE USE OR OTHER DEALINGS IN THE SOFTWARE.

