

1 Functional description

The bus coupler XB-EC-12 connects the EtherCAT network and the ctrlX I/O system. The bus coupler supplies the connected I/O modules with the logic voltage U_L and the peripheral voltage U_P .



Fig. 1: XB-EC-12 module

For a system description of the ctrlX I/O modules, refer to the media directory www.boschrexroth.com/mediadirectory and enter the search term "R911423458".

Ensure that the current documentation is consulted. For the current documentations, go to www.boschrexroth.com/mediadirectory and enter the module type as search term.

For the integration into the parent system, the respective ESI files are available. For the ESI files, go to <http://www.boschrexroth.com/electrics>, search term "ESI-Files".

2 Ordering data

2.1 Bus coupler

Type	Part number	Description
XB-EC-12	R911406090	Bus coupler for EtherCAT including power connector and endcover

2.2 Power connector, 24 V

Ordering code	Part number	Description
XACC-1-CSPWRM	R911416670	24 V power connector

2.3 End clamp

Ordering code	Part number	Description
SUP-M01-END-HALTER	R911170685	2 pieces of snap-on end brackets for 35 mm NS 35/7.5 support rail; width: 9.5 mm

2.4 End cover

Ordering code	Part number	Description
XACC-2-END-COVR	R911412178	End cover

2.5 Documentation

Title	Part number
Project Planning Manual, Security Manual	→ R911342562

For more ordering data (accessories), go to the product catalog under www.boschrexroth.com/electrics.

The type plate of the bus coupler is under the endcover, positioned at the right of the module.

3 Technical data

3.1 General technical data

	XB-EC-12
Connection technique	Push-in terminal
Nominal voltage (U_L , U_P)	DC 24 V (19.2 V to 30 V, including tolerance and residual ripple) PELV/SELV (safety extra-low voltage)
Current consumption U_L at a nominal voltage of 24 V	Max. 60 mA (without I/O modules), 3 A max. (complete system with I/O modules)
Current consumption U_P at a nominal voltage of 24 V	Typ. 7 mA (without I/O modules), 8 A max. (complete system with I/O modules)
Power consumption U_L at a nominal voltage of 24 V	Max. 1.44 W (without I/O modules), 72 W max. (complete system with I/O modules)
Power consumption U_P at a nominal voltage of 24 V	Typ. 0.17 W (without I/O modules), 192 W max. (complete system with I/O modules)
Max. power consumption of the module	2.64 W
Fuse protection (U_L)	Internal with a protective fuse
Fuse protection (U_P)	No internal fuse protection. The operator has to provide protection against overload by an external fuse.
Reverse polarity protection (U_L , U_P)	Present
Overvoltage protection U_L and U_P	Present, fuses can trigger in case of overvoltage.
Transient protection U_L and U_P	Present, suppressor diodes, pulse load up to 1500 W
Voltage dips at current supply interfaces	PS1 < 1 ms, evaluation criterion A
Maximum number of modules per station	30 without boost U_L

	XB-EC-12
Process data width	10 bytes
Configuration	No address or configuration setting required
Dimensions	23.3 mm × 105 mm × 99 mm (width × height × depth)
Weight	115 g (module including connector)
Electrical isolation	DC 1211 V DC U _P to U _L , DC 707 V DC U _P /U _L to FE (not evaluated by UL)
EMC resistance	Acc. to EN 61000-6-2 and EN 61000-6-4
Mounting position	Vertical, on a horizontal support rail
Labeling, approvals	CE, UKCA UL↔ (File No. E210730)

3.2 Internal schematic diagram

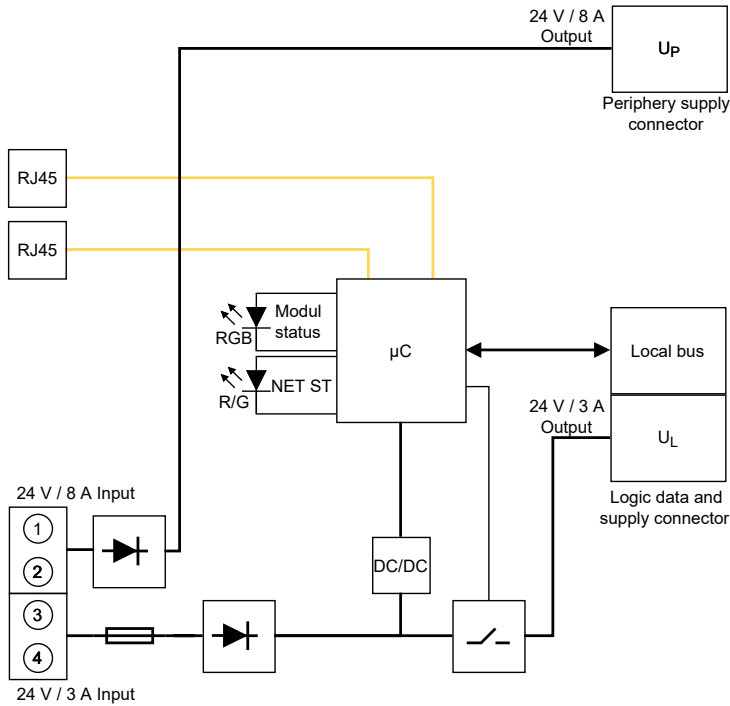

Fig. 2: Internal schematic diagram

3.3 Ambient conditions

Ambient temperature	
Up to 2000 m	-25 to +55 °C
From 2000 m	-25 to +50 °C
From 3000 m	-25 to +45 °C
From 4000 m	-25 to +40 °C
Maximum operating altitude	5000 m
Acc. to DIN 60204	
Ambient temperature (storage and transport)	-40 to +70 °C
Permitted air humidity according to DIN EN 61131-2	
Operation	5 to 95 %
Storage	10 to 95 %
Transport	45 to 95 %
Degree of protection	IP20
Acc. to DIN EN 60 529	(not evaluated by UL)
Protection class	III
Acc. to DIN EN 61010-2-201	
Overvoltage category	2
Acc. to IEC 60664-1	
Contamination level	2, no condensation
Acc. to IEC 61010-1	

NOTICE

Defective device due to contaminated air!

- The ambient air must not contain acids, alkaline solutions, corrosive agents, salts, metal vapors and other electrically conductive contaminants in high concentrations.
- The devices to be installed into the housings and installation compartments must at least comply with the degree of protection IP 54 according to DIN EN 60529.
- The device shall be provided in a suitable fire enclosure in the end-use application.

NOTICE

Defective device due to gases jeopardizing functions

Due to the risk of corrosion, avoid sulphureous gases (e.g. sulphur dioxide (SO₂) and hydrogen sulphide (H₂S)). The device is not resistant against these gases.

NOTICE

Defective device due to overheating

To avoid overheating and to ensure a trouble-free operation of the device, the ambient air has to circulate. Also refer to the section "Installation notes".

3.4 Mechanical tests

Vibration resistance	Oscillations, sinusoidal in all three axes, 5 Hz - 8,4 Hz with 3.5 mm amplitude
Acc. to DIN EN 60068-2-6	8.4 Hz -150 Hz with 1 g peak acceleration
Shock test	Shock stress: Shock resistance in all three axes
Acc. to DIN EN 60068-2-27	11 ms semi-sinusoidal 15 g
Broadband noise	20-500 Hz with 1.22 g RMS (Root Mean Square), 30 min in all three axes
Acc. to DIN EN 60068-2-64	

For the current approvals, go to www.boschrexroth.com/electrics.

4 For your safety

4.1 Intended use

Only use the module as specified in the data sheet.

4.2 User qualification

The product use described in this data sheet is only intended for qualified electricians and staff trained by these qualified electricians. The user has to be familiar with the known safety concepts on automation technology, applicable standards and other guidelines.

4.3 Electric safety

NOTICE

Loss of electric safety

Unintended handling can affect the device safety! Observe the notes in the present data sheet during installation, commissioning and operation.

WARNING

Danger due to dangerous contact voltage

Whenever working on modules and wiring, always switch off the supply voltage and secure it against being switched on again. Observe the safety instructions in the chapter "Installation"!

5 IT security

Operating systems and machines requires the implementation of a comprehensive concept for state-of-the-art IT security. Bosch Rexroth products are part of this comprehensive concept. The properties of the Bosch Rexroth products have to be considered for a comprehensive IT Security concept. For the required properties, refer to the IT Security Guideline (→R911342562).

6 Signal processing

6.1 Synchronizing the application

The application is synchronized in the "SM synchronous" mode.

7 Object directory

7.1 CoE standard objects

The object directory of the module contains objects that can be triggered via SDO services. These are defined in the ETG standards:

Index (hex)	Name
1000	Device type
1001	Error register
1008	Device name
1009	Hardware version
100A	Software version
1018	Identify
10F1	Error settings
10F3	Diagnosis history
10F8	Timestamp object
1Ann	PDO mapping TxPDO
1C00	Sync manager type
1C12	Sync manager 2 assignment
1C13	Sync manager 3 assignment
1C33	SM input parameter
F000	Modular device profile
F100	Device state

Index (hex)	Name
1000	Device type
1001	Error register
1008	Device name
1009	Hardware version
100A	Software version
1018	Identify
10F1	Error settings
10F3	Diagnosis history
10F8	Timestamp object
1Ann	PDO mapping TxPDO
1C00	Sync manager type
1C12	Sync manager 2 assignment
1C13	Sync manager 3 assignment
1C33	SM input parameter
F000	Modular device profile
F100	Device state
F800	Device settings

Index (hex)	Name
1000	Device type
1001	Error register
1008	Device name
1009	Hardware version
100A	Software version
1018	Identify
10F1	Error settings

Index (hex)	Name
10F3	Diagnosis history
10F8	Timestamp object
16nn	PDO mapping RxPDO
1Ann	PDO mapping TxPDO
1C00	Sync manager type
1C12	Sync manager 2 assignment
1C13	Sync manager 3 assignment
1C32	SM output parameter
1C33	SM input parameter
F000	Modular device profile
F100	Device state

7.2 Module-specific CoE objects

Objects with a module-specific design are described in the following table.

Index (hex)	Object name	Data type	Error, warning	Diagnostic number (hex)	Unit
6000	U_P Supply periphery				
6000:01	U _P Voltage	Uint16	–	–	mV
6000:02	U _P Current	Uint16	–	–	mA
6010	U_P Supply logic				
6010:01	U _L Voltage	Uint16	–	–	mV
6010:02	U _L Current	Uint16	–	–	mA
6020	State				
6020:01	U _P Under-voltage	Bit	W	3420	–
6020:02	U _P Over-voltage	Bit	W	3410	–
6020:03	U _P Over-current	Bit	E	2316	–
6020:04	U _L Under-voltage	Bit	W	3421	–
6020:05	U _L Over-voltage	Bit	W	3411	–
6020:06	U _L Over-current	Bit	E	2315	–
8000	System info				
8000:01	Temperature	Int16	W	4210 4220	0.1 °C
8000:02	Power logic used	Uint16	–	–	mW
8000:03	Power logic available	Uint16	–	–	mW
A000:0	Material number	String(20)	–	–	–
A010:0	Full serial number	String(20)	–	–	–

8 Process data

8.1 Process data

The ctrlX CORE^{PLUS} infeed is provided with input data that is inserted into the cyclic process image. This data length is 5 words in total.

The bus coupler is provided with input data that is inserted into the cyclic process image. This data length is 5 words in total.

The process data words from 0 to 4 contain the voltage and current values of U_P and U_L as well as their bits for the supply voltage diagnostics. This information can also be retrieved via acyclic services using CoE. They are shown there as the indices 6000(hex), 6010(hex) and 6020(hex).

Word 1	UINT16	U_P Voltage
Word 2	UINT16	U_P Current
Word 3	UINT16	U_L Voltage
Word 4	UINT16	U_L Current
Word 5		State

Byte 1

Bit 0	U_P Undervoltage
Bit 1	U_P Overvoltage
Bit 2	U_P Overcurrent
Bit 3	U_L Undervoltage
Bit 4	U_L Overvoltage
Bit 5	U_L Overcurrent
Bit 6	Periphery voltage OK
Bit 7	Error

9 Diagnostic strategy

9.1 Mechanisms

Different mechanisms are used for the diagnostics of the module.

Mechanism	Diagnostics
EtherCAT state machine	EtherCAT system diagnostics
EtherCAT hardware watchdog	
Diagnostic objects in the CoE object directory	Extended diagnostics, e.g. peripheral errors
10F1(hex)	Error settings
Diagnosis history object	20 diagnostic messages can be stored
10F3(hex)	Diagnosis history
Module status LED	Shows the general module status
Channel status LED	Signals the channel status or the error states
NET status LED	Signals the EtherCAT slave state

9.2 Diagnosis history

The object 10F3(hex) is implemented as ring memory into the "Overwrite mode". The latest 20 diagnostic messages are stored. Older messages are deleted.







The following table shows the structure of the Diagnosis History object.

Index (hex)	Sub-index	Object name	Data type	Rights	Meaning
10F3		Diagnosis history			Diagnostic statistics
	01	Maximum messages	UINT8	R	Maximum number of messages
	02	Newest message	UINT8	R	Latest message
	03	Newest acknowledged message	UINT8	R/W	Latest confirmed message. Writing "0" deletes the messages in the ring memory.
	04	New messages available	Boolean	R	New message available
	05	Flags	UINT16	R/W	Setting of the object response. Refer to ETG.1020
	06 - 26	Diagnosis message	String	R	Diagnostic message according to ETG.1020

9.3 Status codes

Error, warning	Text ID (hex)	Text
E	2315	Overcurrent at logic power supply U_L
E	2316	Overcurrent at periphery power supply U_P
W	3410	Periphery supply voltage (U_P) is too high
W	3311	Logic supply voltage (U_L) is too high
W	3420	Periphery supply voltage (U_P) is too low
W	3421	Logic supply voltage (U_L) is too low
W	4210	Module temperature too high
W	4220	Module temperature too low

9.4 Module status LED

Device state	LED flashing pattern
Booting	
Initialization	
It is currently configured. Module not yet ready.	
Process data transmission, outputs inactive.	
Module in "Run" state	
Error and warning states	
Logic or peripheral voltage error	
Communication or configuration error	

i One square corresponds to a period of 200 ms. The arrow represents the end of a cycle.

- : LED is not on.
- BU: LED is blue.
- GN: LED is green.
- RD: LED is red.

i A new status is only displayed after the previous flashing cycle has elapsed. A change in status can thus be delayed up to two seconds.

9.5 NET status LED

The NET status LED according to the EtherCAT specification (ETG.1300) displays the EtherCAT bus state at the module.

The operating state is displayed in green .

LED color green	Description
Off	Status INIT
Flickers	Status BOOT
Flashes	Status PRE-OP
Single flash	Status SAFE-OP
Lit	Status OP

The error state is displayed in red .

LED color red	Description
Off	No error
Flickers	Boot error
Flashes	Invalid configuration
Single flash	Local error (e.g. synchronization)
Double flash	Watchdog error
Lit	Communication error

9.6 Channel status LED

The voltage supply input has an LED on the 24V pin.

LED	Meaning
Green	Voltage applied
Off	Voltage missing or incorrectly wired

10 Installation

10.1 Clamping point assignment

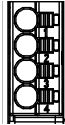
Clamping point	Assignment	Color	Maximum current	LED
	U _P 24 V	Red	8 A	Green
	U _P GND	Blue	8 A	-
	U _L 24 V	Red	3 A	Green
	U _L GND	Blue	3 A	-

10.2 Connection instructions

10.2.1 Connecting EtherCAT network

Connect the EtherCAT to the bus coupler via an 8-pin plug.

The EtherCAT connections are direction-dependent.

Name	Direction	Note
XF25	IN	Line connection from the direction of the master.
XF26	OUT	Line connection in the direction of further slaves.

 Autocrossover: Both Ethernet interfaces are provided with the "Autocrossover" function.

 Shielding: The shield of the connectable twisted-pair wires is electroconductive and connected to the socket. When connecting net segments, avoid ground loops, accidental energization and potential equalization currents via the shielding braid.

 Observe bending radii: The housing dimensions under "Dimensions" refer to the bus coupler with peripheral plugs without Ethernet connection. When installing the bus coupler into a control box, observe the bending radii of the Ethernet cables and the plug connectors used.

To observe the bending radii, use angled RJ45 plugs.

 Installing the Ethernet cable: The Ethernet cable must not be installed or routed outside the building.

Connection method	RJ45 socket ("autonegotiation" and "autocrossing")
Transmission rate	100 MBit/s (full duplex)
Cycle time	125 us min., 10 ms max.
Transmission physics	Ethernet in RJ45-Twisted-Pair
Transmission length	100 m max.

Table 1: EtherCAT interface

10.2.2 Connecting the voltage supply

The voltage supply for logic and peripherals is provided via the front connector. Logic and peripheral voltages are galvanically isolated internally. Both inputs have reverse polarity protection.

Logic voltage supply

The logic voltage and logic current are monitored in the bus coupler. The measured values are provided via the EtherCAT bus.

 In case of overvoltage or undervoltage of U_L, all modules connected to the segment circuit are switched off.

Peripheral voltage supply

The peripheral voltage is measured in the bus coupler and forwarded directly to the I/O modules. The input has no internal protection against overcurrent.

NOTICE

Electronic damages

An overcurrent protective device with a maximum rating of 10 A must be fitted when the device is installed, e.g:

- main circuit breaker to UL489(*) (B-, C-, D-, K- or Z-characteristics)
- Class CC or Class J fuse acc. to UL248(*)

The overcurrent protective devices marked with "*" should be used in installations conforming to UL standards.

External power supply unit

▲ WARNING

Danger of lethal injury due to hazardous electric voltage

- Connect power supply units generating protective extra-low voltage (24 V) only to supply voltages designed for these power supply units. Note the overvoltage categories (refer to the documentation of the power supply unit).
- Do not apply the supply voltage to the protective extra-low voltage.

All control components are supplied from 24 V voltage supplies (SELV/PELV).

The power supply units used have to be able to deliver the quadruple nominal current of the internal and external fuses to ensure that the fuse reliably triggers in case of an error.

All lines of the 24 V voltage supply have to be routed separately from lines carrying higher voltages.

All peripherals, such as digital sensors or actuators connected to the interfaces of the control, also have to comply with the criteria of safety-separated circuits.

 The 24 V voltage supply can be grounded. For more detailed information, refer to the documentation of the power supply unit.

 Use only power supply units that can bridge a half-wave failure (10 ms) at the maximum load connected.

10.3 Connection example

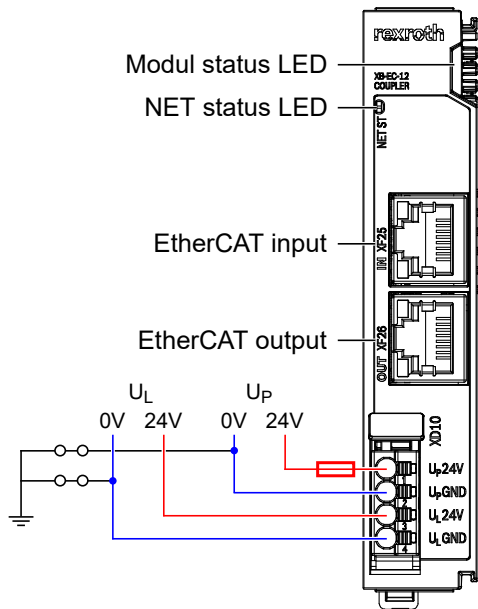

Fig. 3: Connection example with electrical isolation

10.3.1 Setup with electrical isolation

Provide electrical isolation between the logic supply U_L and the periphery supply U_P of the I/O terminals acc. to DIN EN 60204-1. Accordingly, the voltage U_L (24 V logic voltage) at the bus coupler is electrically isolated from the peripheral voltages U_P (24 V segment voltage).

10.3.2 Connecting the reference conductor to the protective conductor

If the reference conductor 0 V (U_L , U_P) is connected to the protective conductor system, this connection has to be arranged at a central place (e.g. at the load power supply unit). Hence, the supply current circuit is a PELV circuit.

10.4 Installation notes

NOTICE

Device destruction due to electrostatic discharge

The device contains components that can be damaged or destroyed by electrostatic discharge. Comply with the required safety measures against electrostatic discharge (ESD) acc. to EN 61340-5-1 when operating the module.

- Mounting location
The module has the degree of protection IP 20 and is thus intended for use in a closed control cabinet or control box (terminal box) with the degree of protection IP 54 or higher. The control cabinet fulfills the function of the final safety enclosure. The modules must be installed in the final safety enclosure. They have to be provided with sufficient rigidity according to UL 61010-1, 61010-2-201 and have to meet the requirements with regard to fire propagation.
- End clamps
Fasten end clamps of the type SUP-M01-ENDHALTER (R911170685) on both sides of the station. End clamps ensure the correct fastening on the support rail and are used as lateral end elements. Always fasten one end clamp of the station before mounting the station. This ensures the following:
 - It impedes the shifting of the modules
 - The installation place for the end clamps is secured.
- Support rail
Mount the module on a 35 mm standard support rail. Only use a support rail TH 35-7.5 acc. to EN 60715. The fastening distance of the support rails may not exceed 200 mm. This distance is required to ensure stability while mounting and dismantling the module.

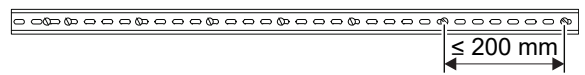

- Provide the following minimum distances for sufficient cooling:

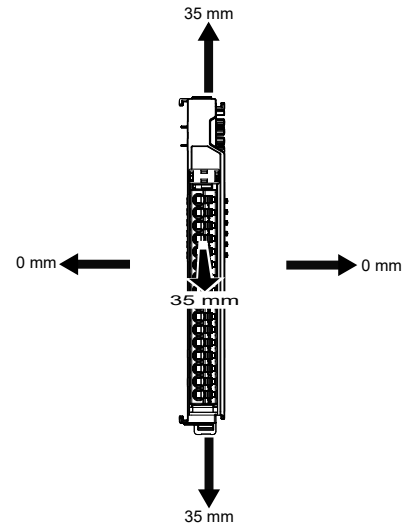

Fig. 4: Ventilation distance

- Additionally, provide sufficient distance for mounting, dismounting, plugs and cables.
- If more devices are connected in series to the station on the left or right, the surface temperature may not exceed 60° C
- In case of a several line design, the supply air has to be measured under each line and its limit value may not be exceeded. For the permitted ambient temperatures, refer to the chapter "Ambient conditions".

10.5 Mounting the ctrlX I/O module

▲ WARNING

Possible personal injury during plug assembly under voltage

For voltages outside SELV/PELV, the plug may only be mounted or dismantled in a de-energized state.

NOTICE

Damage of the device by plug mounting under voltage!

Disconnect the module and all connected module components from voltage before mounting or dismantling.

NOTICE

Damage of the device by short circuit of patch connectors

There is an endcover on the right upon delivery of the bus coupler. Remove this endcover to connect the modules at the bus coupler in series. Position the endcover on the last module of the station to protect it against short circuit and contamination.

NOTICE

Possible damage to property due to unintended mounting of the support rail

- Connect the support rail to a functional earth.
- Mount the module on a support rail.
- Install the module in a control cabinet or in an appropriate housing.

NOTICE

Module is not fixed correctly due to open support arm mounting!

Before mounting, ensure that the support arm mounting of the control is not in open position. If required, release the clamping of the open position using the locking lever, refer to the following figure 5.

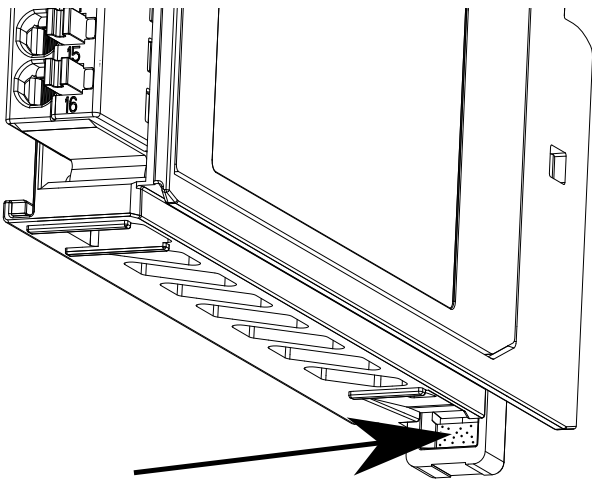

Fig. 5: Locking lever to release the clamping of the open position.

Each module has to be snapped separately.

10.6 Positioning plugs

1. Position the plug on the connector holder, see ①.
2. The plug engages at the locking lever, see ②

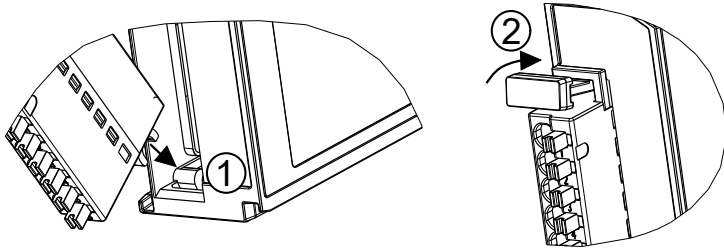

Fig. 6: Positioning plug

10.7 Notes on the electrical connection

- To avoid EMC interferences due to loop formation, 24 V voltage potential and ground (GND) have to be connected in star shape from the 24 V power supply unit to the connections for logic voltage (U_L) and peripheral voltage (U_P). Twin wire end ferrules to loop the potentials are thus not required.
- Use only insulated copper wires suitable for at least 75 °C.
- Use only insulated copper wires suitable for at least 60 °C.

10.7.1 The plug and its functions

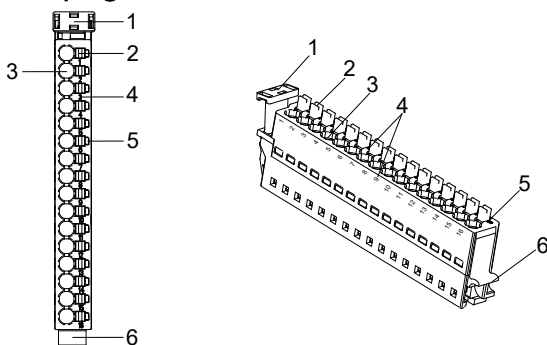

Fig. 7: Plug overview

- ① Locking lever
- ② Pusher
- ③ Clamping point
- ④ Clamping point labeling
- ⑤ Status display
- ⑥ Rotation axis

10.7.2 Tools

- Use the "Phoenix Crimpfox 6" crimping plier to crimp wire end ferrules. The ordering number is: "1212034 Crimpfox 6" at Phoenix Contact.
- Use a slotted screwdriver with a 2.5 mm blade.

10.7.3 Permitted strands

- Solid core
Stripping length: 8.5 mm \pm 0.5 mm, burr-free
- Braid without wire end ferrule
Stripping length: The length of the stripped and 360° twisted braid has to be 8.5 mm \pm 0.5 mm
- Braid with wire end ferrule
- Use a cable cross-section corresponding to the current (minimum 0.2 mm², maximum 1.5 mm²) to avoid an excessive increase in temperature. A cable cross-section of 1.5 mm² is specified for the power supply (U_P) of 8 A. The minimum cable cross-section for the power supply (U_L) is 0.75 mm².
- The insulation of the cables used has to correspond to the rated voltage.

10.7.4 Wire end ferrules

- Wire end ferrules with and without insulating collar are permitted with a contact length of 8 mm according to DIN 46228.
- Maximum dimensions of the crimped wire end ferrule:
Height 1.45 mm
Width 2.34 mm
- Twin wire end ferrules are not permitted in the ctrlX I/O system.

10.7.5 Orientation of the wire end ferrules

- The orientation of the wire end ferrule in the clamping point has to be vertical.

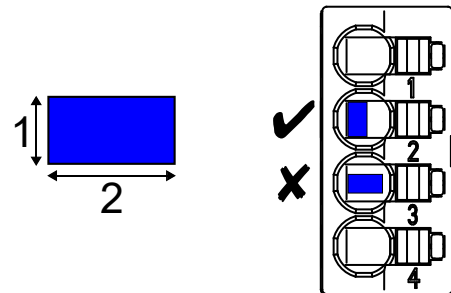

Fig. 8: Orientation of the wire end ferrules in the clamping point

- 1 Height of the crimped wire end ferrule
- 2 Width of the crimped wire end ferrule

10.7.6 Mounting strands

- Press the pusher with a suitable slotted screwdriver.
- Insert the strand into the terminal point as far as possible.
- Release the pusher.

10.7.7 Unmounting strands

- Press the pusher with a suitable slotted screwdriver.
- Remove strands.
- Release the pusher.

10.7.8 Mounting notes for UL certification

Permitted strands

- Use a braid with wire end ferrules for UL devices.
- The following wire end ferrules are permitted:
 - Wire end ferrules with insulating collar as per the table:

Cable cross-section in AWG	Cable cross-section mm ²	Ordering numbers of the wire end ferrules (Weidmüller company)
24 AWG	0.2 mm ²	9025760000, 500 pieces
22 AWG	0.35 mm ²	9025770000, 500 pieces
20 AWG	0.5 mm ²	0690700000, 500 pieces 1476230000, 100 pieces
18 AWG	0.75 mm ²	0462900000, 500 pieces 1476240000, 100 pieces
-	1 mm ²	0463000000, 500 pieces 1476250000, 100 pieces
16 AWG	1.5 mm ²	0463100000, 500 pieces 1476270000, 100 pieces

Strand orientation

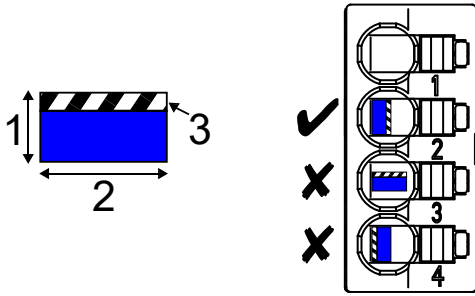

Fig. 9: Orientation of the wire end ferrules in the clamping point

- 1 Height of the crimped wire end ferrule
- 2 Width of the crimped wire end ferrule
- 3 Crimped side of the wire end ferrule

10.8 Removing plug

1. Press the locking lever of the plug at the top, see ①
2. Remove the plug, see ②.

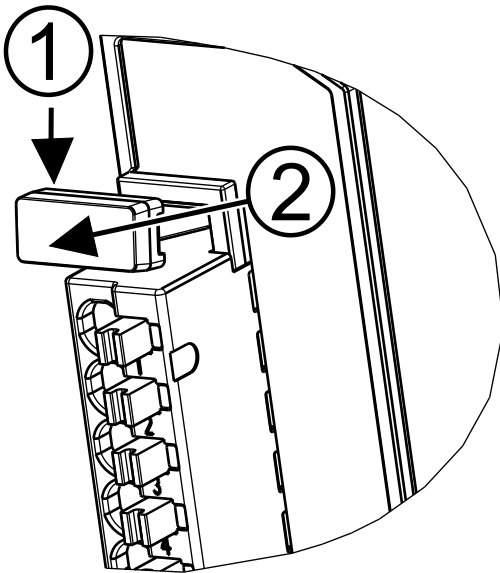

Fig. 10: Removing plug

10.9 Dismounting module

⚠ For dismounting, use a common tool such as a slotted screwdriver with a 2.5 mm blade.

NOTICE

Destruction of components and devices due to mounting and dismounting under voltage!

Disconnect the module and all connected module components from voltage before mounting or dismounting.

Removing module from support rail

1. Use a suitable tool (e.g. slotted screwdriver) and put it into the lower disengaging mechanism (base latch) of the module and disengage the module (see (A) in the following figure). The base latch is locked in the open position.
2. Remove the module vertically to the support rail [see (B) in the following figure].

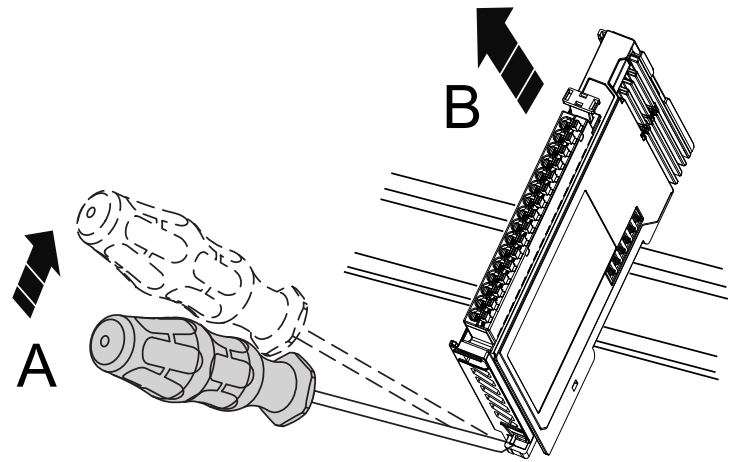

Fig. 11: Removing module from support rail

⚠ Before mounting the module on the support rail again, release the clamping of the open position again. Press the locking lever, refer to the figure 5.

11 Firmware update via FoE

⚠ WARNING

Risk of injury due to unsafe machine states

The machine has to be in a safe state before updating.

The firmware of the module can be updated via FoE. For new firmware files, go to www.boschrexroth.com/mediadirectory and search for the type code of the module.

The firmware module can be updated with all EtherCAT masters supporting the file download via FoE. The module has to be in the BOOTSTRAP state. Entering a password or a file name is not required.

If the update has been completed successfully, the module is restarted as soon as the module state changes from BOOTSTRAP to another state. The reloaded firmware is started.

⚠ Do not disconnect the voltage supply of the module during the file transfer.

Please note that the logic voltage supply is temporarily interrupted for the following modules when completing the firmware update of the bus coupler and a subsequent restart.

⚠ If switching to INIT is not possible, disconnect the ctrlX I/O from the power supply and connect it again.

⚠ The new firmware version might require an updated description file in the Engineering to use new functions. For details, refer to the release notes.

Check whether the latest version of the description file is installed.

11.1 ctrlX I/O Engineering

Within ctrlX I/O Engineering, the required user interface is only displayed for modules supporting a firmware update.

1. First change to the active state in ctrlX I/O Engineering by enabling "Show online data". This is the requirement to update the firmware. The corresponding user interface tab is only displayed if the requirement is met.
2. To open the device editor, double-click on the module in the ctrlX I/O Engineering device tree and select the "FoE" tab.
3. In the "Download" section, select the firmware file (*.EFW) under "Local file name". Ensure that this is the correct file for the module to be updated.
4. Check that the option "Required state" is active under "Details" and that BOOTSTRAP is selected.

5. Use the "Download" button to start the firmware update.

12 License information

12.1 EtherCAT®



The ctrlX I/O modules use EtherCAT® technology. "EtherCAT®" is a registered trademark and patented technology licensed by the Beckhoff Automation GmbH, Germany. EtherCAT is an open, internationally standardized standard and developed further by the "EtherCAT Technology Group" (ETG).

12.2 Libhydrogen

ISC License

Copyright (c) 2017-2019, Frank Denis

Permission to use, copy, modify, and/or distribute this software for any purpose with or without fee is hereby granted, provided that the above copyright notice and this permission notice appear in all copies.

THE SOFTWARE IS PROVIDED "AS IS" AND THE AUTHOR DISCLAIMS ALL WARRANTIES WITH REGARD TO THIS SOFTWARE INCLUDING ALL IMPLIED WARRANTIES OF MERCHANTABILITY AND FITNESS. IN NO EVENT SHALL THE AUTHOR BE LIABLE FOR ANY SPECIAL, DIRECT, INDIRECT, OR CONSEQUENTIAL DAMAGES OR ANY DAMAGES WHATSOEVER RESULTING FROM LOSS OF USE, DATA OR PROFITS, WHETHER IN AN ACTION OF CONTRACT, NEGLIGENCE OR OTHER TORTIOUS ACTION, ARISING OUT OF OR IN CONNECTION WITH THE USE OR PERFORMANCE OF THIS SOFTWARE.

12.3 Ring-buffer

The MIT License (MIT)

Copyright (c) 2014, Anders Kalør

Permission is hereby granted, free of charge, to any person obtaining a copy of this software and associated documentation files (the "Software"), to deal in the Software without restriction, including without limitation the rights to use, copy, modify, merge, publish, distribute, sublicense, and/or sell copies of the Software, and to permit persons to whom the Software is furnished to do so, subject to the following conditions: The above copyright notice and this permission notice shall be included in all copies or substantial portions of the Software.

THE SOFTWARE IS PROVIDED "AS IS", WITHOUT WARRANTY OF ANY KIND, EXPRESS OR IMPLIED, INCLUDING BUT NOT LIMITED TO THE WARRANTIES OF MERCHANTABILITY, FITNESS FOR A PARTICULAR PURPOSE AND NONINFRINGEMENT. IN NO EVENT SHALL THE AUTHORS OR COPYRIGHT HOLDERS BE LIABLE FOR ANY CLAIM, DAMAGES OR OTHER LIABILITY, WHETHER IN AN ACTION OF CONTRACT, TORT OR OTHERWISE, ARISING FROM, OUT OF OR IN CONNECTION WITH THE SOFTWARE OR THE USE OR OTHER DEALINGS IN THE SOFTWARE.

