

1 Functional description

The digital input module XI120116 is used to detect binary GND-switching in a ctrlX I/O station. The module has 16 channels in a 1-wire technique. The signal state is shown at the channel LED on the removable peripheral connector. The logic and peripheral supply as well as the EtherCAT-based module communication are routed through the module.



For an application manual of the ctrlX I/O modules, refer to the media directory www.boschrexroth.com/mediadirectory and enter the search term "R911423458".

Ensure that the current documentation is consulted. For the current documentations, go to www.boschrexroth.com/mediadirectory and enter the module type as search term.

For the integration into the parent system, the respective ESI files are available. For the ESI files, go to <http://www.boschrexroth.com/electrics>, search term "ESI-Files".

2 Ordering data

Type	Part number	Description
XI120116	R912009221	16-channel digital input module NPN, DC 24 V, 3 ms input filter, 1-wire

For more ordering data (accessories), go to the product catalog under www.boschrexroth.com/electrics.

3 Technical data

3.1 General technical data

Number of inputs	16
Connection method	Push-in terminal
Connection technique	1-wire technique
Specification	EN 61131-2
Input filter	3 ms

Signal voltage "0"	18 V to 30 V
Signal voltage "1"	0 V to 7 V
Input current	Typ. 3 mA
Nominal voltage (U_L / U_P)	DC 24 V (19.2 V to 30 V, including tolerance and residual ripple) PELV/SELV (safety extra-low voltage)
Current consumption U_L	30 mA
Current consumption U_P	46 mA
Max. power consumption of the module	1.87 W
Bit width in the process image	2 bytes (16 bits)
Configuration	No address or configuration setting required
Dimensions	12 mm × 105 mm × 99 mm (Width × height × depth)
Weight	100 g (module including connector)
Electrical isolation	1211 V DC U_P to U_L , 707 V DC U_P/U_L to FE (not evaluated by UL)
EMC resistance	Acc. to EN 61000-6-2 and EN 61000-6-4
Mounting position	Vertical, on a horizontal mounting rail
Labeling, approvals	CE, UKCA, UL

3.2 Internal schematic diagram

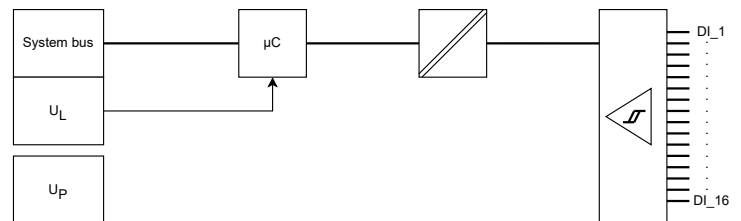

3.3 Ambient conditions

Ambient temperature	
≤ 2,000 m	-25 to +55 °C
2,000 m to 3,000 m	-25 to +50 °C
3,000 m to 4,000 m	-25 to +45 °C
4,000 m to 5,000 m	-25 to +40 °C
Maximum operating altitude	
Acc. to DIN 60204	5,000 m
Ambient temperature (storage and transport)	-40 to +70 °C
Permitted air humidity according to DIN EN 61131-2	
(Operation, storage, transport)	10 to 95 %
Degree of protection	IP20
Acc. to DIN EN 60 529	(not evaluated by UL)
Protection class	III
Acc. to DIN EN 61010-2-201	
Overvoltage category	2
Acc. to IEC 60664-1	
Contamination level	2, no condensation
Acc. to EN 61010-1	

NOTICE**Defective device due to contaminated air**

- The ambient air must not contain acids, alkaline solutions, corrosive agents, salts, metal vapors and other electrically conductive contaminants in high concentrations.
- The devices to be installed into the housings and installation compartments must at least comply with the degree of protection IP 54 according to DIN EN 60529.
- The device shall be provided in a suitable fire enclosure in the end-use application.

NOTICE**Defective device due to gases jeopardizing functions**

Due to the risk of corrosion, avoid sulphurous gases (e.g. sulphur dioxide (SO₂) and hydrogen sulphide (H₂S)). The device is not resistant against these gases.

NOTICE**Defective device due to overheating**

To avoid overheating and to ensure a trouble-free operation of the device, the ambient air has to circulate. Also refer to the section "Installation notes".

3.4 Mechanical tests

Vibration resistance Acc. to DIN EN 60068-2-6	Oscillations, sinusoidal in all three axes, 5 Hz - 8,4 Hz with 3.5 mm amplitude 8.4 Hz -150 Hz with 1 g peak acceleration
Shock test Acc. to DIN EN 60068-2-27	Shock stress: Shock resistance in all three axes 11 ms semi-sinusoidal 15 g
Broadband noise Acc. to DIN EN 60068-2-64	20-500 Hz with 1.22 g RMS (Root Mean Square), 30 min in all three axes

 For the current approvals, go to www.boschrexroth.com/electrics.

4 For your safety

4.1 Intended use

Use the module only as specified in the data sheet.

4.2 User qualification

The product use described in this data sheet is only intended for qualified electricians and staff trained by these qualified electricians. The user has to be familiar with the known safety concepts on automation technology, applicable standards and other guidelines.

4.3 Electrical safety

NOTICE**Loss of electric safety**

Unintended handling can affect the device safety! Observe the notes in the present data sheet during installation, commissioning and operation.

5 Signal processing

5.1 Synchronizing the application

The application is synchronized in the "SM synchronous" mode.

6 Process data

6.1 Process data of the module

The module is a simple module with a device emulation. Apart from the registers of the EtherCAT slave, no further objects are available for configuration or status.

The following process data is transferred:

Index (hex)	Object name	Data type	Access	Description	Default (hex)
6000:01	Value	BOOL	RO	Channel 1 Value	0
6010:01	Value	BOOL	RO	Channel 2 Value	0
6020:01	Value	BOOL	RO	Channel 3 Value	0
6030:01	Value	BOOL	RO	Channel 4 Value	0
6040:01	Value	BOOL	RO	Channel 5 Value	0
6050:01	Value	BOOL	RO	Channel 6 Value	0
6060:01	Value	BOOL	RO	Channel 7 Value	0
6070:01	Value	BOOL	RO	Channel 8 Value	0
6080:01	Value	BOOL	RO	Channel 9 Value	0
6090:01	Value	BOOL	RO	Channel 10 Value	0
60A0:01	Value	BOOL	RO	Channel 11 Value	0
60B0:01	Value	BOOL	RO	Channel 12 Value	0
60C0:01	Value	BOOL	RO	Channel 13 Value	0
60D0:01	Value	BOOL	RO	Channel 14 Value	0
60E0:01	Value	BOOL	RO	Channel 15 Value	0
60F0:01	Value	BOOL	RO	Channel 16 Value	0

Table 1: Input process data







7 Diagnostic strategy

7.1 Mechanisms



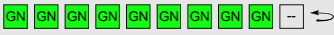

Different mechanisms are used for the diagnostics of the module.

Mechanism	Diagnostics
EtherCAT state machine	EtherCAT system diagnostics
EtherCAT hardware watchdog	
Module status LED	Shows the general module status
Channel status LED	Signals the channel status or the error states

7.2 Module status LED

Device state	LED flashing pattern
Booting	 ↷
Initialization	 ↷
It is currently configured. Module not yet ready.	 ↷
Process data transmission, outputs inactive.	 ↷
Module in "Run" state	 ↷
Error and warning states	
Logic or peripheral voltage error	 ↷
Communication or configuration error	 ↷

 One square corresponds to a period of 200 ms. The arrow represents the end of a cycle.

-  LED is not on.
-  LED is blue.
-  LED is green.
-  LED is red.

 A new status is only displayed after the previous flashing cycle has elapsed. A change in status can thus be delayed up to two seconds.

7.3 Channel status LED

Each channel of the module is provided with a channel status LED at the respective signal pin of the plug.

LED	Logic signal state
Off	0
Green	1

8 Installation

8.1 Clamping point assignment

Clamping point	Assignment	Color
1	1 - DI channel 1	Grey
2	2 - DI channel 2	Grey
3	3 - DI channel 3	Grey
4	4 - DI channel 4	Grey
5	5 - DI channel 5	Grey
6	6 - DI channel 6	Grey
7	7 - DI channel 7	Grey
8	8 - DI channel 8	Grey
9	9 - DI channel 9	Grey
10	10 - DI channel 10	Grey
11	11 - DI channel 11	Grey
12	12 - DI channel 12	Grey
13	13 - DI channel 13	Grey
14	14 - DI channel 14	Grey
15	15 - DI channel 15	Grey
16	16 - DI channel 16	Grey

Table 2: Clamping point assignment

Provide the potential reference of the channels via U_P 24 V or use the potential distribution terminal XI821116 (16 × GND) with the part number R911406125 or XI824116 (8 × DC 24 V, 8 × GND) with the part number R911406125.

8.2 Connection example

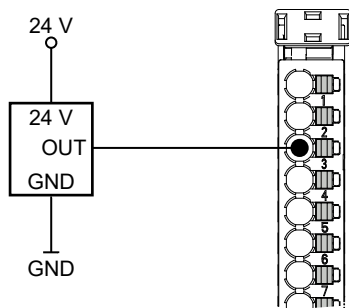

Fig. 1: 1-wire sensor

8.3 Mounting and installation

The application manual for the ctrlX I/O modules contains notes on installation, mounting and dismounting. For the application description, go to:

- ➔ www.boschrexroth.com/MediaDirectory,
Search term: ➔ "R911423458"
or
- ➔ <https://docs.automation.boschrexroth.com/doc/4126711705/ctrlx-i-o-anwendungsbeschreibung/latest/en/>.

NOTICE

Destruction of the device due to non-compliance with the application manual

Follow the mounting instructions in the application manual to ensure a correct mounting and to prevent damage to the device.

9 License information

9.1 EtherCAT®

EtherCAT®

The ctrlX I/O modules use EtherCAT® technology. "EtherCAT®" is a registered trademark and patented technology licensed by the Beckhoff Automation GmbH, Germany. EtherCAT is an open, internationally standardized standard and developed further by the "EtherCAT Technology Group" (ETG).

