

1 Functional description

The relay output module XI232302 is intended for use in a ctrlX I/O station. The module has two channels with changeover contacts designed for AC 250 V and 2 A. The channels are independent of each other and led out potential-free. The switching state of the respective channel is indicated on the LED on the detachable peripheral connector.

The logic and peripheral supply as well as the EtherCAT-based module communication are routed through the module.



Fig. 1: Module XI232302

i For an application manual of the ctrlX I/O modules, refer to the media directory www.boschrexroth.com/mediadirectory and enter the search term ["R911423458"](http://www.boschrexroth.com/mediadirectory).

i Ensure that the current documentation is consulted. For the current documentations, go to www.boschrexroth.com/mediadirectory and enter the module type as search term.

i For the integration into the parent system, the respective ESI files are available. For the ESI files, go to <http://www.boschrexroth.com/electrics>, search term ["ESI-Files"](http://www.boschrexroth.com/electrics).

2 Ordering data

Type	Part number	Description
XI232302	R911420202	2-channel relay module (AC 250 V, 2 A)

i For more ordering data (accessories), go to the product catalog under www.boschrexroth.com/electrics.

3 Technical data

3.1 General technical data

XI232302	
Number of channels	2, Changeover contact
Connection method	Push-in

XI232302	
Load types	Ohmic, inductive
Switching voltage	AC 12 V to 250 V (50/60 Hz) DC 12 V to 250 V
Maximum switching current for common use and resistive use	2 A at AC \leq 250 V 2 A at DC \leq 30 V
Maximum switching current for "pilot duty" use	0.15 A at DC \leq 250 V
Short-time inrush current	Triple overload
Minimum load	100 mA (DC 12 V)
Overload protection	External fuse required
Switching frequency max.	6/min (at nominal load)
Response time max.	12 ms
Bounce time max.	8 ms
Release time max.	5 ms
Cycles mech. (min.)	10×10^6
Cycles electr. (min.)	6×10^5
Nominal voltage (U_L/U_P)	DC 24 V (19.2 V to 30 V, including tolerance and residual ripple) PELV/SELV (safety extra-low voltage)
Current consumption U_L	29 mA
Current consumption U_P	25 mA
Max. power consumption of the module	1.2 W
Bit width in the process image	2 Bits
Configuration	No address or configuration settings required
Dimensions	12 mm \times 105 mm \times 99 mm (Width \times height \times depth)
Weight	100 g (module including connector)
Electrical isolation	DC 1200 V U_P to U_L , DC 707 V U_P/U_L to FE, AC 3000 V U_P/U_L to relay contacts, AC 3000 V housing to relay contacts, AC 3000 V relay contacts ch. 1 to ch. 2
EMC resistance	Acc. to EN 61000-6-2 and EN 61000-6-4
Mounting position	Vertical, on a horizontal mounting rail
Labeling, approvals	CE, UKCA, UL

3.2 Internal schematic diagram

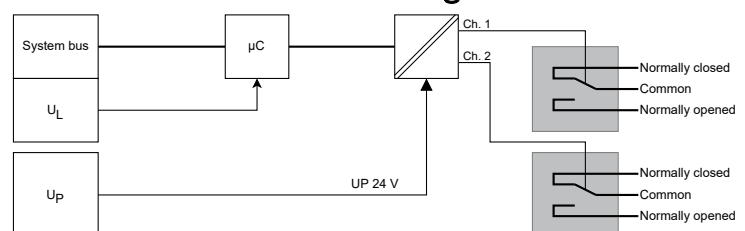

Fig. 2: Internal schematic diagram

3.3 Ambient conditions

Ambient temperature	
≤ 2,000 m	-25 to +55 °C
2,000 m to 3,000 m	-25 to +50 °C
3,000 m to 4,000 m	-25 to +45 °C
4,000 m to 5,000 m	-25 to +40 °C
Maximum operating altitude Acc. to DIN 60204	5,000 m
Ambient temperature (storage and transport)	-40 to +70 °C
Permitted air humidity according to DIN EN 61131-2 (Operation, storage, transport)	10 to 95 %
Degree of protection Acc. to DIN EN 60 529	IP20 (not evaluated by UL)
Protection class Acc. to DIN EN 61010-2-201	II
Overvoltage category Acc. to IEC 60664-1	2
Contamination level Acc. to EN 61010-1	2, no condensation

NOTICE

Defective device due to contaminated air!

- The ambient air must not contain acids, alkaline solutions, corrosive agents, salts, metal vapors and other electrically conductive contaminants in high concentrations.
- The devices to be installed into the housings and installation compartments must at least comply with the degree of protection IP 54 according to DIN EN 60529.
- The device shall be provided in a suitable fire enclosure in the end-use application.

NOTICE

Defective device due to gases jeopardizing functions

Due to the risk of corrosion, avoid sulphureous gases (e.g. sulphur dioxide (SO₂) and hydrogen sulphide (H₂S)). The device is not resistant against these gases.

NOTICE

Defective device due to overheating

To avoid overheating and to ensure a trouble-free operation of the device, the ambient air has to circulate. Also refer to the section "Installation notes".

3.4 Mechanical tests

Vibration resistance Acc. to DIN EN 60068-2-6	Oscillations, sinusoidal in all three axes, 5 Hz - 8,4 Hz with 3.5 mm amplitude 8.4 Hz -150 Hz with 1 g peak acceleration
Shock test Acc. to DIN EN 60068-2-27	Shock stress: Shock resistance in all three axes 11 ms semi-sinusoidal 15 g
Broadband noise Acc. to DIN EN 60068-2-64	20-500 Hz with 1.22 g RMS (Root Mean Square), 30 min in all three axes

 For the current approvals, go to www.boschrexroth.com/electrics.

4 For your safety

4.1 Intended use

Use the module only as specified in the data sheet.

4.2 User qualification

The product use described in this data sheet is only intended for qualified electricians and staff trained by these qualified electricians. The user has to be familiar with the known safety concepts on automation technology, applicable standards and other guidelines.

4.3 Electrical safety

NOTICE

Loss of electric safety

Unintended handling can affect the device safety! Observe the notes in the present data sheet during installation, commissioning and operation.

WARNING

Danger due to dangerous contact voltage

Whenever working on modules and wiring, always switch off the supply voltage and secure it against being switched on again. Observe the safety instructions in the chapter "Installation"!

5 Process data

5.1 Process data of the module

The module has a device emulation without support of CoE objects. Apart from the tabs of the EtherCAT slave, no other objects and status objects are available for configuration. The following process data is transferred:

Word 1			
	Byte 1		
		Bit 0	Out Channel 1 Value
		Bit 1	Out Channel 2 Value







6 Diagnostic strategy

6.1 Mechanisms





Different mechanisms are used for the diagnostics of the module.

Mechanism	Diagnostics
EtherCAT state machine	EtherCAT system diagnostics
EtherCAT hardware watchdog	
Module status LED	Shows the general module status
Channel status LED	Signals the channel status or the error states

6.2 Module status LED

Device state	LED flashing pattern
Booting	
Initialization	
It is currently configured. Module not yet ready.	
Process data transmission, outputs inactive.	
Module in "Run" state	
Error and warning states	
Logic or peripheral voltage error	
Communication or configuration error	

 One square corresponds to a period of 200 ms. The arrow represents the end of a cycle.

-  LED is not on.
-  LED is blue.
-  LED is green.
-  LED is red.

ⓘ A new status is only displayed after the previous flashing cycle has elapsed. A change in status can thus be delayed up to two seconds.

6.3 Channel status LED

The status LED indicates the switching state of the respective relay on the channel.

LED	Meaning
Off (supply voltage U_P is not applied)	Connection of the common contact to the normally-closed contact
Yellow	Connection of the common contact to the normally-closed contact
Green	Connection of the common contact to the normally-opened contact

7 Installation

7.1 Clamping point assignment

Clamping point	Pin	Signal	LED
1	1	closed, no function	Status LED Channel 1
2	2	Channel 1 normally closed	Not available
3	3	Channel 1 common	Not available
4	4	Channel 1 normally opened	Not available
5	5	closed, no function	Status LED Channel 2
6	6	Channel 2 normally closed	Not available
7	7	Channel 2 common	Not available
8	8	Channel 2 normally opened	Not available

7.2 Connection instructions

7.2.1 Connection and installation instructions

⚠ WARNING

Danger due to dangerous contact voltage

Dangerous contact voltage when working on circuits that do not meet the requirements for protective extra-low voltage (PELV)!

Noncompliance with this note may result in adverse health effects, up to and including life-threatening injuries.

- Only mount and demount the ctrlX I/O modules disconnected from voltage!
- Whenever working on modules and wiring, always switch off the supply voltage and secure it against being switched on again and check the modules are disconnected from voltage.
- Install a separate, designated disconnecting switch
- Install the ctrlX I/O modules for the low-voltage range exclusively in the control cabinet or terminal box!
They must comply with the requirements concerning electrical and fireproof enclosures in accordance with the following standards:
 - EN 50178 or EN 61010-1
 - UL 61010-1 (for applications with UL approval)

⚠ WARNING

Danger due to dangerous touch voltage in case of earth faults

Operate the ctrlX I/O modules for the low-voltage range exclusively in grounded networks.

NOTICE

Electronic damages

Limit the channel current according to the specification with an external back-up fuse in front of the common inputs PIN 3 and PIN 7.

7.3 Connection example

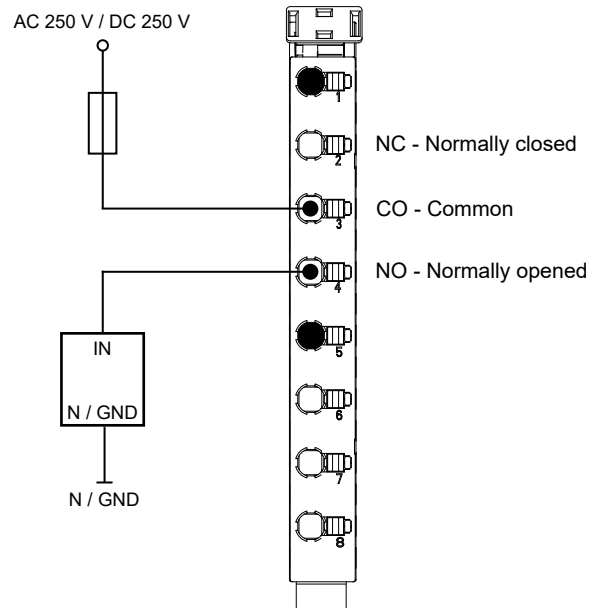

Fig. 3: Connection example

The connection requires a fuse against overload.

In this example, the relay switches to the neutral conductor (N) for connection in AC voltage systems or to GND for connection in DC voltage systems.

7.4 Mounting and installation

The application manual for the ctrlX I/O modules contains notes on installation, mounting and dismounting. For the application description, go to:

- www.boschrexroth.com/MediaDirectory, Search term: "R911423458" or
- <https://docs.automation.boschrexroth.com/doc/4126711705/ctrlx-i-o-anwendungsbeschreibung/latest/en/>.

NOTICE

Destruction of the device due to non-compliance with the application manual

Follow the mounting instructions in the application manual to ensure a correct mounting and to prevent damage to the device.

NOTICE

Device destruction due to electrostatic discharge

The device contains components that can be damaged or destroyed by electrostatic discharge. Comply with the required safety measures against electrostatic discharge (ESD) acc. to EN 61340-5-1 when operating the module.

- Mounting location
The module has the degree of protection IP 20 and is thus intended for use in a closed control cabinet or control box (terminal box) with the degree of protection IP 54 or higher. The control cabinet fulfills the function of the final safety enclosure. The modules must be installed in the final safety enclosure. They have to be provided with sufficient rigidity according to UL 61010-1, 61010-2-201 and have to meet the requirements with regard to fire propagation.
- End clamps
Fasten end clamps of the type SUP-M01-ENDHALTER (R911170685) on both sides of the station. End clamps ensure the correct fastening on the support rail and are

used as lateral end elements. Always fasten one end clamp of the station before mounting the station. This ensures the following:

- It impedes the shifting of the modules
- The installation place for the end clamp is secured.

- Endcover

At the end of each ctrlX I/O station, slide an endcover of type XACC-2-END-COVR onto the last module. The endcover is included in the scope of delivery of the bus coupler. Sliding on the endcover ensures protection against accidental contact.

- Mounting rail

Mount the module on a 35 mm standard support rail. Use only a TH 35-7.5 support rail acc. to EN 60715. The fastening distance of the support rails may not exceed 200 mm. This distance is required to ensure stability while mounting and dismantling the module.

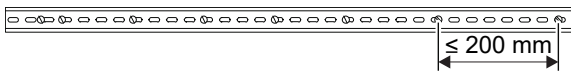

- Provide the following minimum distances for sufficient cooling:

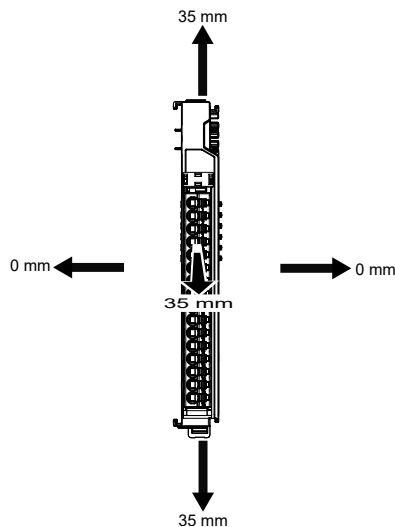

Fig. 4: Ventilation distances

- Additionally, provide sufficient distance for mounting, dismantling, plugs and cables.
- If more devices are connected in series to the station on the left or right, the surface temperature may not exceed 60° C
- In case of a several line design, the supply air has to be measured under each line and its limit value may not be exceeded. For permitted values, refer to the chapter "Ambient conditions" of the respective module data sheet.

7.4.1 Mounting the ctrlX I/O module

▲ WARNING

Possible personal injury during plug assembly under voltage

For voltages outside SELV/PELV, the plug may only be mounted or dismantled in a de-energized state.

NOTICE

Damage of the device by plug mounting under voltage!

Disconnect the module and all connected module components from voltage before mounting or dismantling.

NOTICE

Damage of the device by short circuit of patch connectors

There is an endcover on the right upon delivery of the bus coupler. Remove this endcover to connect the modules at the bus coupler in series. Position the endcover on the last module of the station to protect it against short circuit and contamination.

NOTICE

Possible damage to property due to unintended mounting of the support rail

- Connect the support rail to a functional earth.
- Mount the module on a support rail.
- Install the module in a control cabinet or in an appropriate housing.

NOTICE

Module is not fixed correctly due to open support arm mounting!

Before mounting, ensure that the support arm mounting of the control is not in open position. If required, release the clamping of the open position using the locking lever, refer to the following figure Fig. 5.

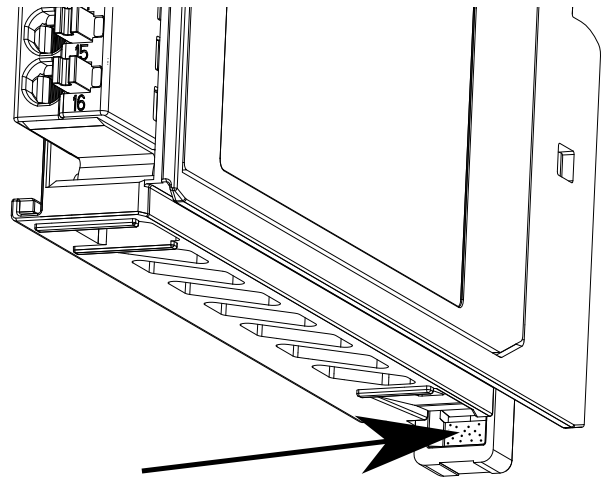

Fig. 5: Locking lever to release the clamping of the open position.

Each module has to be snapped separately.

7.4.2 Positioning plug

1. Position the plug on the connector holder, see ①.
2. The plug engages at the locking lever, see ②

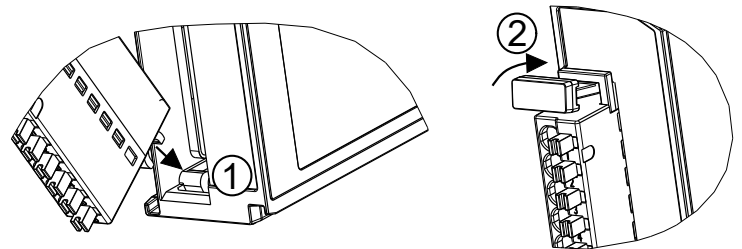

Fig. 6: Positioning plug

7.4.3 Removing plug

1. Press the locking lever of the plug at the top, see ①
2. Remove the plug, see ②.

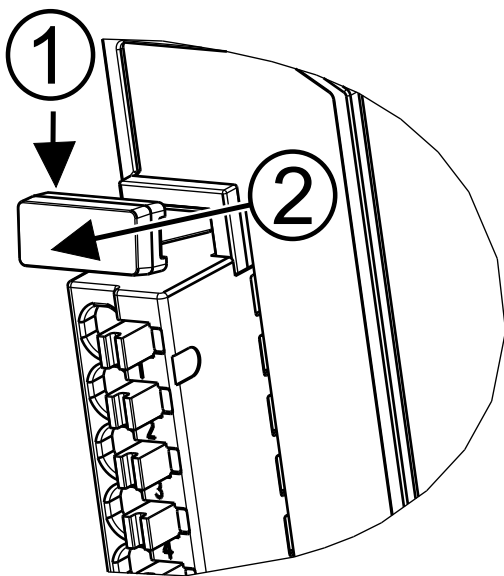

Fig. 7: Removing plug

7.4.4 Dismounting module

For dismounting, use a common tool such as a slotted screwdriver with a 2.5 mm blade.

NOTICE

Destruction of components and devices due to mounting and dismounting under voltage!

Disconnect the module and all connected module components from voltage before mounting or dismounting.

Removing module from support rail

1. Use a suitable tool (e.g. slotted screwdriver) and put it into the lower disengaging mechanism (base latch) of the module and disengage the module (see (A) in the following figure). The base latch is locked in the open position.
2. Remove the module vertically to the support rail [see (B) in the following figure].

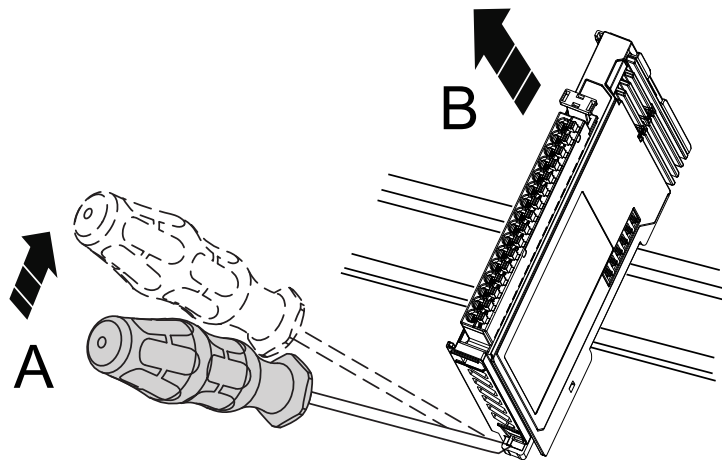

Fig. 8: Removing module from support rail

Before mounting the module on the support rail again, release the clamping of the open position. Press the locking lever, refer to the figure Fig. 5.

7.4.5 Electric installation

Notes on the electrical connection

- To avoid EMC interferences due to loop formation, 24 V voltage potential and ground (GND) have to be connected in star shape from the 24 V power supply unit to the connections for logic voltage (U_L) and peripheral voltage (U_P).
- Use only insulated copper wires suitable for at least 75 °C.

Tools

- Use the "Phoenix Crimpfox 6" crimping plier to crimp wire end ferrules. The ordering number is: "1212034 Crimpfox 6" at Phoenix Contact.
- Use a slotted screwdriver with a 2.5 mm blade.

Permitted lines

- Rigid lines
Stripping length: 8.5 mm \pm 0.5 mm, burr-free
- Flexible line without wire end ferrule
Stripping length: The length of the stripped and 360° twisted braids has to be 8.5 mm \pm 0.5 mm
- Flexible line with wire end ferrule
- Use a cable cross-section corresponding to the current (minimum 0.2 mm², maximum 1.5 mm²) to avoid an excessive increase in temperature. A cable cross-section of 1.5 mm² is specified for the power supply (U_P) of 8 A. The minimum cable cross-section for the power supply (U_L) is 0.75 mm².
- The insulation of the cables used has to correspond to the rated voltage.

Wire end ferrules

- Wire end ferrules with and without insulating collar are permitted with a contact length of 8 mm according to DIN 46228.
- Maximum dimensions of the crimped wire end ferrule:
Height 1.45 mm
Width 2.34 mm
- Twin wire end ferrules are not permitted.

Orientation of the wire end ferrules

- The orientation of the wire end ferrule in the clamping point has to be vertical.

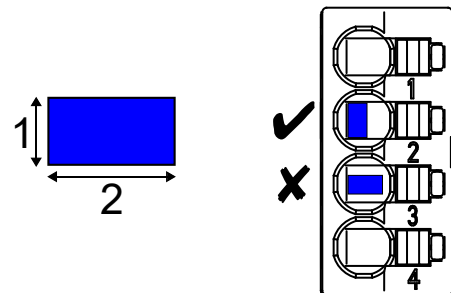

Fig. 9: Orientation of the wire end ferrules in the clamping point

- 1 Height of the crimped wire end ferrule
- 2 Width of the crimped wire end ferrule

Installing lines

- Press the pusher with a suitable slotted screwdriver.
- Insert the line into the clamping point as far as possible.
- Release the pusher.

Uninstalling lines

- Press the pusher with a suitable slotted screwdriver.
- Remove line.
- Release the pusher.

Mounting notes for UL certification

Permitted lines

- Use flexible lines with wire end ferrules for UL devices.
- The following wire end ferrules are permitted:
 - Wire end ferrules with insulating collar as per the table:

Cable cross-section in AWG	Cable cross-section mm ²	Ordering numbers of the wire end ferrules (Weidmüller company)
24 AWG	0.2 mm ²	9025760000, 500 pieces
22 AWG	0.35 mm ²	9025770000, 500 pieces
20 AWG	0.5 mm ²	0690700000, 500 pieces 1476230000, 100 pieces
18 AWG	0.75 mm ²	0462900000, 500 pieces 1476240000, 100 pieces
-	1 mm ²	0463000000, 500 pieces 1476250000, 100 pieces
16 AWG	1.5 mm ²	0463100000, 500 pieces 1476270000, 100 pieces

Orientation of wire end ferrules

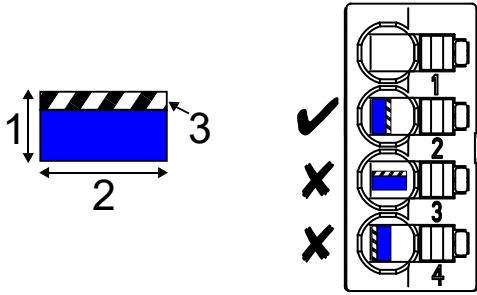

Fig. 10: Orientation of the wire end ferrules in the clamping point

- 1 Height of the crimped wire end ferrule
- 2 Width of the crimped wire end ferrule
- 3 Crimped side of the wire end ferrule

8 License information

8.1 EtherCAT®



The ctrlX I/O modules use EtherCAT® technology. "EtherCAT®" is a registered trademark and patented technology licensed by the Beckhoff Automation GmbH, Germany. EtherCAT is an open, internationally standardized standard and developed further by the "EtherCAT Technology Group" (ETG).

