

1 Functional description

The digital output module XI213204 is used to output binary 24 V control signals with a maximum current of 2 A in a ctrlX I/O station. The module has four channels in a 2-wire technique. The signal state is shown at the channel LED on the removable peripheral connector. The digital outputs are fed via the 24 V supply from U_P .

The logic and peripheral voltage supply as well as the EtherCAT-based module communication are routed through the module.



Fig. 1: Module XI213204

i For an application manual of the ctrlX I/O modules, refer to the media directory www.boschrexroth.com/mediadirectory and enter the search term www.boschrexroth.com/mediadirectory and enter the search term www.boschrexroth.com/mediadirectory and enter the search term "R911423458".

i Ensure that the current documentation is consulted. For the current documentations, go to www.boschrexroth.com/mediadirectory and enter the module type as search term.

i For the integration into the parent system, the respective ESI files are available. For the ESI files, go to <http://www.boschrexroth.com/electrics>, search term "ESI-Files".

2 Ordering data

Type	Part number	Description
XI213204	R911417209	Digital output module 4-channel, DC 24 V, 2 A, 2-wire

i For more ordering data (accessories), go to the product catalog under www.boschrexroth.com/electrics.

3 Technical data

3.1 General technical data

XI213204	
Number of outputs	4
Connection method	Push-in
Connection technique	2-wire technique
Output current max.	2.0 A per channel The GND contact assigned to the channel may not be loaded with more than the maximum output current of 2 A.
Total current of channels	<50 °C: 6 A >50°C: 4 A
Nominal load	Ohmic, 48 W max. (12 Ω; at nominal voltage)
Minimum load	10 kΩ
Rising time (T_{Rise})	Without load: 16.4 μs on the digital input 17.3 μs at 240 Ω, 100 mA Ohmic nominal load: 17.6 μs at 12 Ω, 2000 mA
Fall time (T_{FALL})	Without load: 450 μs on the digital input 45.3 μs at 240 Ω, 100 mA Ohmic nominal load: 22.4 μs at 12 Ω, 2000 mA
Inductive switch-off energy	150 mJ max. per channel
Overload response	Granular switch-off with automatic restart
Feedback voltage resistance	Not resistant to feedback, external measures required
Nominal voltage (U_L/U_P)	DC 24 V (19.2 V to 30 V, including tolerance and residual ripple) PELV/SELV (safety extra-low voltage)
Current consumption U_L	30 mA
Current consumption U_P	15 mA + load
Max. power consumption of the module	2.2 W
Bit width in the process image	4 bits
Configuration	No address or configuration setting required
Dimensions	12 mm × 105 mm × 99 mm (width × height × depth)
Weight	90 g (module including connector)
Electrical isolation	DC 1200 V U_P to U_L , DC 707 V U_P/U_L to FE, tested for 60 s each (not evaluated by UL)

	XI213204
EMC resistance	Acc. to EN 61000-6-2 and EN 61000-6-4
Mounting position	Vertical, on a horizontal mounting rail
Labeling, approvals	CE, UKCA, UL

	8.4 Hz -150 Hz with 1 g peak acceleration
Shock test Acc. to DIN EN 60068-2-27	Shock stress: Shock resistance in all three axes 11 ms semi-sinusoidal 15 g
Broadband noise Acc. to DIN EN 60068-2-64	20-500 Hz with 1.22 g RMS (Root Mean Square), 30 min in all three axes

3.2 Internal schematic diagram

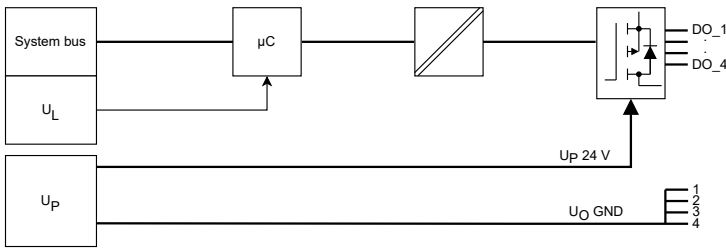

Fig. 2: Internal schematic diagram

3.3 Ambient conditions

Ambient temperature ≤ 2,000 m	-25 to +55 °C
2,000 m to 3,000 m:	-25 to +50 °C
3,000 m to 4,000 m:	-25 to +45 °C
4,000 m to 5,000 m:	-25 to +40 °C
Maximum operating altitude Acc. to DIN 60204	5,000 m
Ambient temperature (storage and transport)	-40 to +70 °C
Permitted air humidity according to DIN EN 61131-2 (Operation, storage, transport)	10 to 95 %
Degree of protection Acc. to DIN EN 60 529	IP20 (not evaluated by UL)
Protection class Acc. to DIN EN 61010-2-201	III
Overvoltage category Acc. to IEC 60664-1	2
Contamination level Acc. to EN 61010-1	2, no condensation

NOTICE

Defective device due to contaminated air!

- The ambient air must not contain acids, alkaline solutions, corrosive agents, salts, metal vapors and other electrically conductive contaminants in high concentrations.
- The devices to be installed into the housings and installation compartments must at least comply with the degree of protection IP 54 according to DIN EN 60529.
- The device shall be provided in a suitable fire enclosure in the end-use application.

NOTICE

Defective device due to gases jeopardizing functions

Due to the risk of corrosion, avoid sulphureous gases (e.g. sulphur dioxide (SO₂) and hydrogen sulphide (H₂S)). The device is not resistant against these gases.

NOTICE

Defective device due to overheating

To avoid overheating and to ensure a trouble-free operation of the device, the ambient air has to circulate. Also refer to the section "Installation notes".

3.4 Mechanical tests

Vibration resistance Acc. to DIN EN 60068-2-6	Oscillations, sinusoidal in all three axes, 5 Hz - 8,4 Hz with 3.5 mm amplitude
--	---

For the current approvals, go to www.boschrexroth.com/electrics.

4 For your safety

4.1 Intended use

Use the module only as specified in the data sheet.

4.2 User qualification

The product use described in this data sheet is only intended for qualified electricians and staff trained by these qualified electricians. The user has to be familiar with the known safety concepts on automation technology, applicable standards and other guidelines.

4.3 Electrical safety

NOTICE

Loss of electric safety

Unintended handling can affect the device safety! Observe the notes in the present data sheet during installation, commissioning and operation.

5 Signal processing

5.1 Synchronizing the application

The application is synchronized in the "SM synchronous" mode.

6 Process data

6.1 Process data of the module

The module is a simple module with a device emulation. Apart from the registers of the EtherCAT slave, no further objects are available for configuration or status. The following process data is transferred:

Word 1	Byte 1	Bit 0	Out	Channel 1 Value
		Bit 1	Out	Channel 2 Value
		Bit 2	Out	Channel 3 Value
		Bit 3	Out	Channel 4 Value

7 Diagnostic strategy

7.1 Mechanisms

Different mechanisms are used for the diagnostics of the module.

Mechanism	Diagnostics
EtherCAT state machine	EtherCAT system diagnostics
EtherCAT hardware watchdog	
Module status LED	Shows the general module status
Channel status LED	Signals the channel status or the error states

7.2 Module status LED

Device state	LED flashing pattern
Booting	BU BU BU BU BU -- -- -- -- -- ↷
Initialization	BU BU BU BU BU BU BU BU BU BU BU ↷
It is currently configured. Module not yet ready.	GN GN GN GN GN -- -- -- -- -- ↷
Process data transmission, outputs inactive.	GN GN GN GN GN GN GN GN GN GN -- ↷
Module in "Run" state	GN GN GN GN GN GN GN GN GN GN GN ↷
Error and warning states	
Logic or peripheral voltage error	RD RD RD RD RD RD RD RD RD RD RD ↷
Communication or configura- tion error	RD RD RD RD RD -- -- -- -- -- ↷

! One square corresponds to a period of 200 ms.
The arrow represents the end of a cycle.

- LED is not on.
- BU LED is blue.
- GN LED is green.
- RD LED is red.

! A new status is only displayed after the previous flashing cycle has elapsed. A change in status can thus be delayed up to two seconds.

7.3 Channel status LED

Each channel of the module is provided with a channel status LED at the respective signal pin of the plug.

LED	Logic signal state
Off	0
Green	1

8 Installation

8.1 Clamping point assignment

Clamping point	Assignment	Color
1	1 - DO CH.1	Grey
2	2 - U ₀ GND	Dark blue
3	3 - DO CH.2	Grey
4	4 - U ₀ GND	Dark blue
5	5 - DO CH.3	Grey
6	6 - U ₀ GND	Dark blue
7	7 - DO CH.4	Grey
8	8 - U ₀ GND	Dark blue

- ! The channel GND outputs are only to be used as reference potential for the respective output channel.
- These outputs may not be used as peripheral supply GND.
 - To supply the connected actuators, use the potential distribution modules, e.g. XI821116.

8.2 Switching off inductive loads

Negative voltages are generated when inductive loads are switched off. If the switch-off energies are greater than specified in the technical data, these switch-off energies can cause damage to the electronics of the module.

NOTICE
Electronic damage due to overload
Use a suitable external freewheeling circuit to protect the module from high voltages when switching off inductive loads.

8.3 Pin example

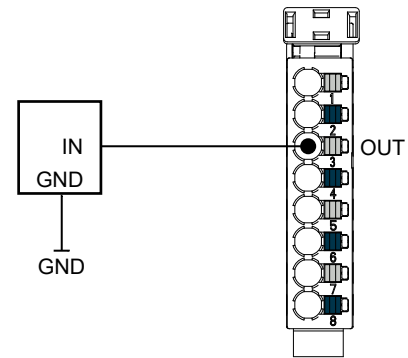

Fig. 3: One-wire actuator

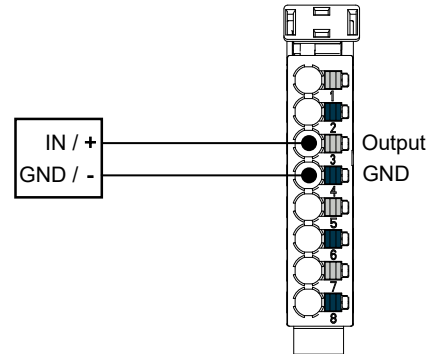

Fig. 4: Two-wire actuator

8.4 Mounting and installation

The application manual for the ctrlX I/O modules contains notes on installation, mounting and dismounting. For the application description, go to:

- ↗ www.boschrexroth.com/MediaDirectory,
Search term: ↗ "R911423458"
- or
- ↗ <https://docs.automation.boschrexroth.com/doc/4126711705/ctrlx-i-o-anwendungsbeschreibung/latest/en/>.

NOTICE
Destruction of the device due to non-compliance with the application manual
Follow the mounting instructions in the application manual to ensure a correct mounting and to prevent damage to the device.

NOTICE
Device destruction due to electrostatic discharge
The device contains components that can be damaged or destroyed by electrostatic discharge. Comply with the required safety measures against electrostatic discharge (ESD) acc. to EN 61340-5-1 when operating the module.

- Mounting location
The module has the degree of protection IP 20 and is thus intended for use in a closed control cabinet or control box (terminal box) with the degree of protection IP 54 or higher. The control cabinet fulfills the function of the final safety enclosure. The modules must be installed in the final safety enclosure. They have to be provided with sufficient rigidity according to UL 61010-1, 61010-2-201 and have to meet the requirements with regard to fire propagation.
- End clamps
Fasten end clamps of the type SUP-M01-ENDHALTER (R911170685) on both sides of the station. End clamps ensure the correct fastening on the support rail and are used as lateral end elements. Always fasten one end clamp of the station before mounting the station. This ensures the following:
 - It impedes the shifting of the modules
 - The installation place for the end clamp is secured.
- Endcover

At the end of each ctrlX I/O station, slide an endcover of type XACC-2-END-COVR onto the last module. The endcover is included in the scope of delivery of the bus coupler. Sliding on the endcover ensures protection against accidental contact.

- Mounting rail

Mount the module on a 35 mm standard support rail. Use only a TH 35-7.5 support rail acc. to EN 60715. The fastening distance of the support rails may not exceed 200 mm. This distance is required to ensure stability while mounting and dismantling the module.



- Provide the following minimum distances for sufficient cooling:

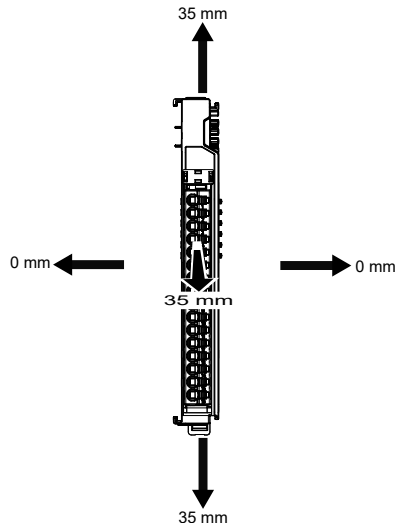

Fig. 5: Ventilation distances

- Additionally, provide sufficient distance for mounting, dismantling, plugs and cables.
- If more devices are connected in series to the station on the left or right, the surface temperature may not exceed 60° C
- In case of a several line design, the supply air has to be measured under each line and its limit value may not be exceeded. For permitted values, refer to the chapter "Ambient conditions" of the respective module data sheet.

8.4.1 Mounting the ctrlX I/O module

NOTICE
Damage of the device by plug mounting under voltage!
 Disconnect the module and all connected module components from voltage before mounting or dismantling.

NOTICE
Damage of the device by short circuit of patch connectors
 There is an endcover on the right upon delivery of the bus coupler. Remove this endcover to connect the modules at the bus coupler in series. Position the endcover on the last module of the station to protect it against short circuit and contamination.

NOTICE
Possible damage to property due to unintended mounting of the support rail

- Connect the support rail to a functional earth.
- Mount the module on a support rail.
- Install the module in a control cabinet or in an appropriate housing.

NOTICE
Module is not fixed correctly due to open support arm mounting!

Before mounting, ensure that the support arm mounting of the control is not in open position. If required, release the clamping of the open position using the locking lever, refer to the following figure Fig. 6.

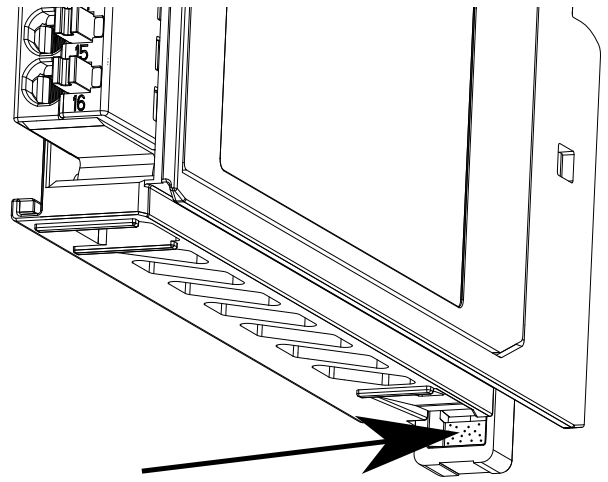

Fig. 6: Locking lever to release the clamping of the open position.

Each module has to be snapped separately.

8.4.2 Positioning plug

1. Position the plug on the connector holder, see ①.
2. The plug engages at the locking lever, see ②

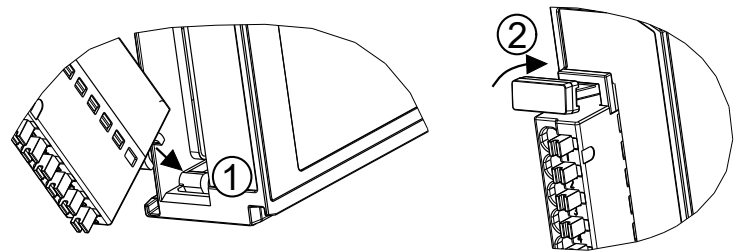

Fig. 7: Positioning plug

8.4.3 Removing plug

1. Press the locking lever of the plug at the top, see ①
2. Remove the plug, see ②.

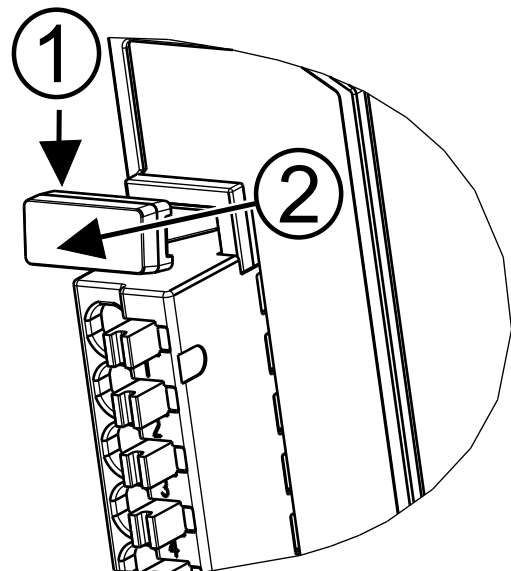

Fig. 8: Removing plug

8.4.4 Dismounting module

⚠ For dismantling, use a common tool such as a slotted screwdriver with a 2.5 mm blade.

NOTICE
Destruction of components and devices due to mounting and dismantling under voltage!

Disconnect the module and all connected module components from voltage before mounting or dismantling.

Removing module from support rail

1. Use a suitable tool (e.g. slotted screwdriver) and put it into the lower disengaging mechanism (base latch) of the module and disengage the module (see (A) in the following figure). The base latch is locked in the open position.
2. Remove the module vertically to the support rail [see (B) in the following figure].

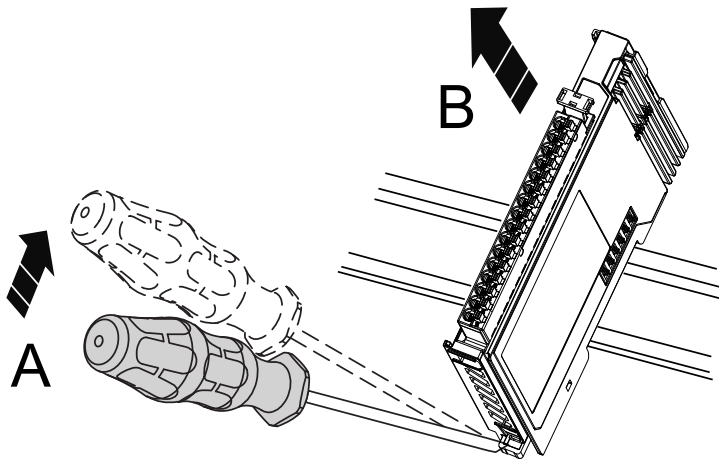

Fig. 9: Removing module from support rail

Before mounting the module on the support rail again, release the clamping of the open position again. Press the locking lever, refer to the figure Fig. 6.

8.4.5 Electric installation

Notes on the electrical connection

- To avoid EMC interferences due to loop formation, 24 V voltage potential and ground (GND) have to be connected in star shape from the 24 V power supply unit to the connections for logic voltage (U_L) and peripheral voltage (U_P).
- Use only insulated copper wires suitable for at least 75 °C.

Tools

- Use the "Phoenix Crimpfox 6" crimping plier to crimp wire end ferrules. The ordering number is: "1212034 Crimpfox 6" at Phoenix Contact.
- Use a slotted screwdriver with a 2.5 mm blade.

Permitted lines

- Rigid lines
Stripping length: 8.5 mm \pm 0.5 mm, burr-free
- Flexible line without wire end ferrule
Stripping length: The length of the stripped and 360° twisted braids has to be 8.5 mm \pm 0.5 mm
- Flexible line with wire end ferrule
- Use a cable cross-section corresponding to the current (minimum 0.2 mm², maximum 1.5 mm²) to avoid an excessive increase in temperature. A cable cross-section of 1.5 mm² is specified for the power supply (U_P) of 8 A. The minimum cable cross-section for the power supply (U_L) is 0.75 mm².
- The insulation of the cables used has to correspond to the rated voltage.

Wire end ferrules

- Wire end ferrules with and without insulating collar are permitted with a contact length of 8 mm according to DIN 46228.
- Maximum dimensions of the crimped wire end ferrule:
Height 1.45 mm
Width 2.34 mm
- Twin wire end ferrules are not permitted.

Orientation of the wire end ferrules

- The orientation of the wire end ferrule in the clamping point has to be vertical.

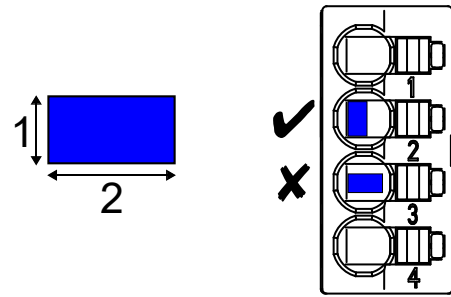

Fig. 10: Orientation of the wire end ferrules in the clamping point

- 1 Height of the crimped wire end ferrule
- 2 Width of the crimped wire end ferrule

Installing lines

- Press the pusher with a suitable slotted screwdriver.
- Insert the line into the clamping point as far as possible.
- Release the pusher.

Uninstalling lines

- Press the pusher with a suitable slotted screwdriver.
- Remove line.
- Release the pusher.

Mounting notes for UL certification

Permitted lines

- Use flexible lines with wire end ferrules for UL devices.
- The following wire end ferrules are permitted:
 - Wire end ferrules with insulating collar as per the table:

Cable cross-section in AWG	Cable cross-section mm ²	Ordering numbers of the wire end ferrules (Weidmüller company)
24 AWG	0.2 mm ²	9025760000, 500 pieces
22 AWG	0.35 mm ²	9025770000, 500 pieces
20 AWG	0.5 mm ²	0690700000, 500 pieces 1476230000, 100 pieces
18 AWG	0.75 mm ²	0462900000, 500 pieces 1476240000, 100 pieces
-	1 mm ²	0463000000, 500 pieces 1476250000, 100 pieces
16 AWG	1.5 mm ²	0463100000, 500 pieces 1476270000, 100 pieces

Orientation of wire end ferrules

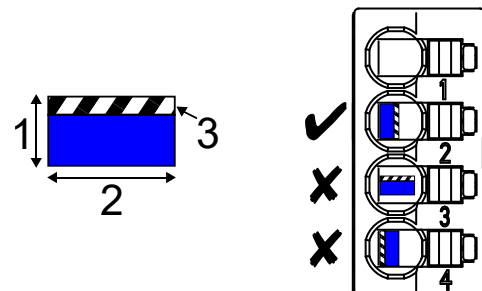

Fig. 11: Orientation of the wire end ferrules in the clamping point

- 1 Height of the crimped wire end ferrule
- 2 Width of the crimped wire end ferrule
- 3 Crimped side of the wire end ferrule

9 License information

9.1 EtherCAT®



The ctrlX I/O modules use EtherCAT® technology. "EtherCAT®" is a registered trademark and patented technology licensed by the Beckhoff Automation GmbH, Germany. EtherCAT is an open, internationally standardized standard and developed further by the "EtherCAT Technology Group" (ETG).

