

## 1 Functional description

The digital input terminal XI110116 is used to detect binary 24 V control signals in a ctrlX I/O station. The terminal has 16 channels in a 1-wire technique. The signal state is shown at the channel LED on the removable peripheral connector. The logic and peripheral supply as well as the EtherCAT-based module communication are routed through the module.



Fig. 1: Module XI110116

**i** For a system description of the ctrlX I/O modules, refer to the media directory [↗ www.boschrexroth.com/mediadirectory](http://www.boschrexroth.com/mediadirectory) and enter the search term [↗](http://www.boschrexroth.com/mediadirectory) "R911423458".

**i** Ensure that the current documentation is consulted. For the current documentations, go to [↗ www.boschrexroth.com/mediadirectory](http://www.boschrexroth.com/mediadirectory) and enter the module type as search term.

**i** For the integration into the parent system, the respective ESI files are available. For the ESI files, go to [↗ http://www.boschrexroth.com/electrics](http://www.boschrexroth.com/electrics), search term [↗](http://www.boschrexroth.com/electrics) "ESI-Files".

## 2 Ordering data

Type	Part number	Description
XI110116	R911406097	Digital Input Terminal 16-channel, DC 24 V, 3 ms Input Filter, 1-wire

**i** For more ordering data (accessories), go to the product catalog under [↗ www.boschrexroth.com/electrics](http://www.boschrexroth.com/electrics).

## 3 Technical data

### 3.1 Technical data

XI110116	
Number of inputs	16
Connection method	Push-in terminal

XI110116	
Connection technique	1-wire technique
Specification	EN 61131-2, type 1/3
Input filter	3 ms
Signal voltage "0"	-3 V... 5 V
Signal voltage "1"	11 V... 30 V
Input current	Typically 2.4 mA
Nominal voltage (U <sub>L</sub> / U <sub>P</sub> )	DC 24 V (19.2 V to 30 V, including tolerance and residual ripple) PELV/SELV (safety extra-low voltage)
Current consumption 30 mA U <sub>L</sub>	
Current consumption 19 mA U <sub>P</sub>	
Max. power consumption of the module	1.89 W
Bit width in the process image	2 bytes (16 bits)
Configuration	No address or configuration setting required
Dimensions	12 mm × 105 mm × 99 mm (width × height × depth)
Weight	100 g (module including connector)
Electrical isolation	1211 V DC U <sub>P</sub> to U <sub>L</sub> , 707 V DC U <sub>P</sub> /U <sub>L</sub> to FE (not evaluated by UL)
EMC resistance	Acc. to EN 61000-6-2 and EN 61000-6-4
Mounting position	Vertical, on a horizontal support rail
Labeling, approvals	CE, UKCA UL (↗ File No. E210730)

### 3.2 Internal schematic diagram

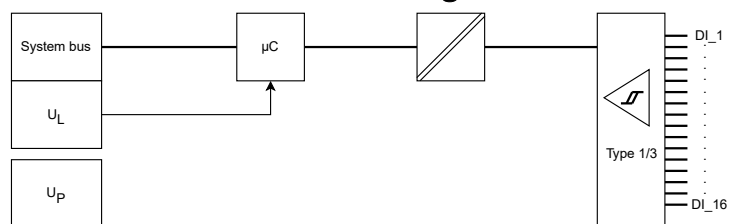

Fig. 2: Internal schematic diagram

### 3.3 Ambient conditions

Ambient temperature	
Up to 2000 m	-25 to +55 °C
From 2000 m	-25 to +50 °C
From 3000 m	-25 to +45 °C
From 4000 m	-25 to +40 °C
Maximum operating altitude	5000 m
Acc. to 60204	
Ambient temperature (storage and transport)	-40 to +70 °C
Permitted air humidity according to DIN EN 61131-2	
Operation	5 to 95 %

Storage	10 to 95 %
Transport	45 to 95 %
Degree of protection Acc. to DIN EN 60 529	IP20 (not evaluated by UL)
Protection class Acc. to DIN EN 61010-2-201	III
Overvoltage category Acc. to IEC 60664-1	2
Contamination level Acc. to IEC 61010-1	2, no condensation

#### NOTICE

##### Defective device due to contaminated air!

- The ambient air must not contain acids, alkaline solutions, corrosive agents, salts, metal vapors and other electrically conductive contaminants in high concentrations.
- The devices to be installed into the housings and installation compartments must at least comply with the degree of protection IP 54 according to DIN EN 60529.
- The device shall be provided in a suitable fire enclosure in the end-use application.

#### NOTICE

##### Defective device due to gases jeopardizing functions

Due to the risk of corrosion, avoid sulphurous gases (e.g. sulphur dioxide (SO<sub>2</sub>) and hydrogen sulphide (H<sub>2</sub>S)). The device is not resistant against these gases.

#### NOTICE

##### Defective device due to overheating

To avoid overheating and to ensure a trouble-free operation of the device, the ambient air has to circulate. Also refer to the section "Installation notes".

## 3.4 Mechanical tests

Vibration resistance Acc. to DIN EN 60068-2-6	Oscillations, sinusoidal in all three axes, 5 Hz - 8,4 Hz with 3.5 mm amplitude 8.4 Hz -150 Hz with 1 g peak acceleration
Shock test Acc. to DIN EN 60068-2-27	Shock stress: Shock resistance in all three axes 11 ms semi-sinusoidal 15 g
Broadband noise Acc. to DIN EN 60068-2-64	20-500 Hz with 1.22 g RMS (Root Mean Square), 30 min in all three axes

🔗 For the current approvals, go to  
[www.boschrexroth.com/electrics](http://www.boschrexroth.com/electrics).

## 4 For your safety

### 4.1 Intended use

Only use the module as specified in the data sheet.

### 4.2 User qualification

The product use described in this data sheet is only intended for qualified electricians and staff trained by these qualified electricians. The user has to be familiar with the known safety concepts on automation technology, applicable standards and other guidelines.

## 4.3 Electric safety

#### NOTICE

##### Loss of electric safety

Unintended handling can affect the device safety! Observe the notes in the present data sheet during installation, commissioning and operation.

## 5 Signal processing

### 5.1 Synchronizing the application

The application is synchronized in the "SM synchronous" mode.

## 6 Process data

### 6.1 Process data of the module

The module is a simple module with a device emulation. Apart from the registers of the EtherCAT slave, no further objects are available for configuration or status.

The following process data is transferred:

#### Word 1

##### Byte 1

Bit 0	IN	Channel 1 Value
Bit 1	IN	Channel 2 Value
Bit 2	IN	Channel 3 Value
Bit 3	IN	Channel 4 Value
Bit 4	IN	Channel 5 Value
Bit 5	IN	Channel 6 Value
Bit 6	IN	Channel 7 Value
Bit 7	IN	Channel 8 Value

##### Byte 2

Bit 0	IN	Channel 9 Value
Bit 1	IN	Channel 10 Value
Bit 2	IN	Channel 11 Value
Bit 3	IN	Channel 12 Value
Bit 4	IN	Channel 13 Value
Bit 5	IN	Channel 14 Value
Bit 6	IN	Channel 15 Value
Bit 7	IN	Channel 16 Value

## 7 Diagnostic strategy

### 7.1 Mechanisms

Different mechanisms are used for the diagnostics of the module.

Mechanism	Diagnostics
EtherCAT state machine	EtherCAT system diagnostics
EtherCAT hardware watchdog	
Module status LED	Shows the general module status
Channel status LED	Signals the channel status or the error states

## 7.2 Module status LED

Device state	LED flashing pattern
Booting	BU BU BU BU BU -- -- -- -- -- ↷
Initialization	BU BU BU BU BU BU BU BU BU BU BU ↷
It is currently configured. Module not yet ready.	GN GN GN GN GN -- -- -- -- -- ↷
Process data transmission, outputs inactive.	GN GN GN GN GN GN GN GN GN GN -- ↷
Module in "Run" state	GN GN GN GN GN GN GN GN GN GN GN ↷
<b>Error and warning states</b>	
Logic or peripheral voltage error	RD RD RD RD RD RD RD RD RD RD RD ↷
Communication or configura- tion error	RD RD RD RD RD -- -- -- -- -- ↷

ⓘ One square corresponds to a period of 200 ms. The arrow represents the end of a cycle.

- : LED is not on.
- BU: LED is blue.
- GN: LED is green.
- RD: LED is red.

ⓘ A new status is only displayed after the previous flashing cycle has elapsed. A change in status can thus be delayed up to two seconds.

## 7.3 Channel status LED

Each channel of the module is provided with a channel status LED at the respective signal pin of the plug.

LED	Logic signal state
Off	0
Green	1

# 8 Installation

## 8.1 Clamping point assignment

Clamping point	Assignment	Color
1	1 - DI channel 1	Grey
2	2 - DI channel 2	Grey
3	3 - DI channel 3	Grey
4	4 - DI channel 4	Grey
5	5 - DI channel 5	Grey
6	6 - DI channel 6	Grey
7	7 - DI channel 7	Grey
8	8 - DI channel 8	Grey
9	9 - DI channel 9	Grey
10	10 - DI channel 10	Grey
11	11 - DI channel 11	Grey
12	12 - DI channel 12	Grey
13	13 - DI channel 13	Grey
14	14 - DI channel 14	Grey
15	15 - DI channel 15	Grey
16	16 - DI channel 16	Grey

Table 1: Clamping point assignment

ⓘ Provide the potential reference of the channels via U<sub>P</sub> 24 V or use the potential distribution terminal XI822116 (16 × DC 24 V) with the part number R911406123 or XI824116 (8 × DC 24 V, 8 × GND) with the part number R911406122.

## 8.2 Connection example

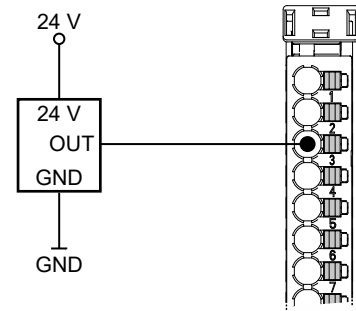

Fig. 3: 1-wire sensor

## 8.3 Installation notes

### NOTICE

#### Device destruction due to electrostatic discharge

The device contains components that can be damaged or destroyed by electrostatic discharge. Comply with the required safety measures against electrostatic discharge (ESD) acc. to EN 61340-5-1 when operating the module.

- **Mounting location**  
The module has the degree of protection IP 20 and is thus intended for use in a closed control cabinet or control box (terminal box) with the degree of protection IP 54 or higher. The control cabinet fulfills the function of the final safety enclosure. The modules must be installed in the final safety enclosure. They have to be provided with sufficient rigidity according to UL 61010-1, 61010-2-201 and have to meet the requirements with regard to fire propagation.
- **End clamps**  
Fasten end clamps of the type SUP-M01-ENDHALTER (R911170685) on both sides of the station. End clamps ensure the correct fastening on the support rail and are used as lateral end elements. Always fasten one end clamp of the station before mounting the station. This ensures the following:
  - It impedes the shifting of the modules
  - The installation place for the end clamps is secured.
- **Support rail**  
Mount the module on a 35 mm standard support rail. Only use a support rail TH 35-7.5 acc. to EN 60715. The fastening distance of the support rails may not exceed 200 mm. This distance is required to ensure stability while mounting and dismantling the module.
- **Provide the following minimum distances for sufficient cooling:**

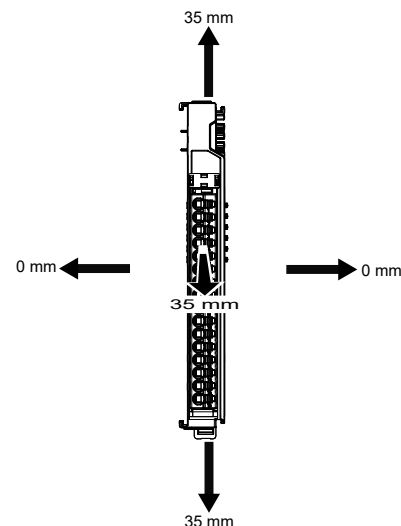
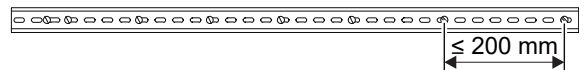

Fig. 4: Ventilation distance

- Additionally, provide sufficient distance for mounting, dismounting, plugs and cables.
- If more devices are connected in series to the station on the left or right, the surface temperature may not exceed 60° C
- In case of a several line design, the supply air has to be measured under each line and its limit value may not be exceeded. For the permitted ambient temperatures, refer to the chapter "Ambient conditions".

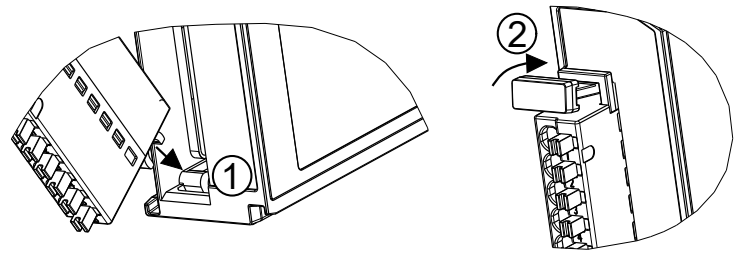

Fig. 6: Positioning plug

## 8.4 Mounting the ctrlX I/O module

### NOTICE

#### Damage of the device by plug mounting under voltage!

Disconnect the module and all connected module components from voltage before mounting or dismounting.

### NOTICE

#### Damage of the device by short circuit of patch connectors

There is an endcover on the right upon delivery of the bus coupler. Remove this endcover to connect the modules at the bus coupler in series. Position the endcover on the last module of the station to protect it against short circuit and contamination.

### NOTICE

#### Possible damage to property due to unintended mounting of the support rail

- Connect the support rail to a functional earth.
- Mount the module on a support rail.
- Install the module in a control cabinet or in an appropriate housing.

### NOTICE

#### Module is not fixed correctly due to open support arm mounting!

Before mounting, ensure that the support arm mounting of the control is not in open position. If required, release the clamping of the open position using the locking lever, refer to the following figure 5.

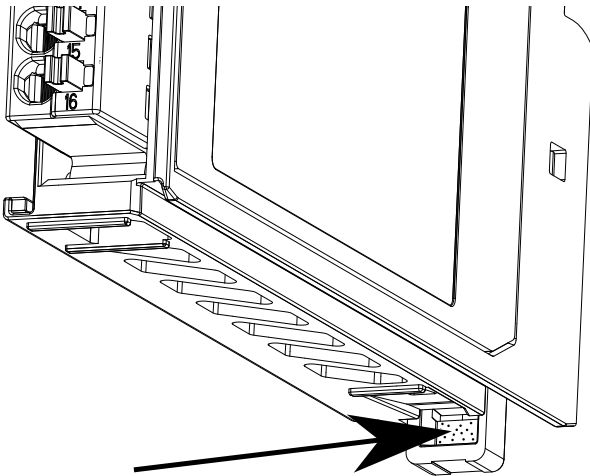

Fig. 5: Locking lever to release the clamping of the open position.

Each module has to be snapped separately.

## 8.5 Positioning plugs

1. Position the plug on the connector holder, see ①.
2. The plug engages at the locking lever, see ②

## 8.6 Notes on the electrical connection

- To avoid EMC interferences due to loop formation, 24 V voltage potential and ground (GND) have to be connected in star shape from the 24 V power supply unit to the connections for logic voltage ( $U_L$ ) and peripheral voltage ( $U_P$ ). Twin wire end ferrules to loop the potentials are thus not required.
- Use only insulated copper wires suitable for at least 75 °C.

### 8.6.1 The plug and its functions

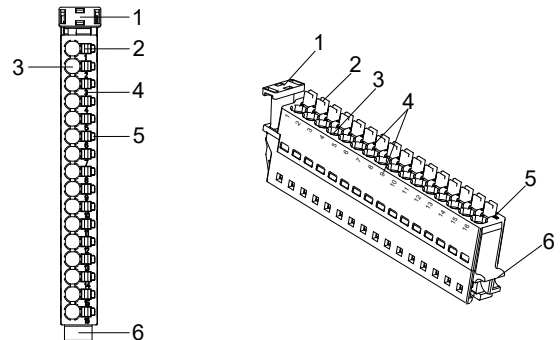

Fig. 7: Plug overview

- ① Locking lever
- ② Pusher
- ③ Clamping point
- ④ Clamping point labeling
- ⑤ Status display
- ⑥ Rotation axis

### 8.6.2 Tools

- Use the "Phoenix Crimpfox 6" crimping plier to crimp wire end ferrules. The ordering number is: "1212034 Crimpfox 6" at Phoenix Contact.
- Use a slotted screwdriver with a 2.5 mm blade.

### 8.6.3 Permitted strands

- Solid core  
Stripping length: 8.5 mm  $\pm$  0.5 mm, burr-free
- Braid without wire end ferrule  
Stripping length: The length of the stripped and 360° twisted braid has to be 8.5 mm  $\pm$  0.5 mm
- Braid with wire end ferrule
- Use a cable cross-section corresponding to the current (minimum 0.2 mm<sup>2</sup>, maximum 1.5 mm<sup>2</sup>) to avoid an excessive increase in temperature. A cable cross-section of 1.5 mm<sup>2</sup> is specified for the power supply ( $U_P$ ) of 8 A. The minimum cable cross-section for the power supply ( $U_L$ ) is 0.75 mm<sup>2</sup>.
- The insulation of the cables used has to correspond to the rated voltage.

### 8.6.4 Wire end ferrules

- Wire end ferrules with and without insulating collar are permitted with a contact length of 8 mm according to DIN 46228.
- Maximum dimensions of the crimped wire end ferrule:  
Height 1.45 mm

Width 2.34 mm

- Twin wire end ferrules are not permitted in the ctrlX I/O system.

### 8.6.5 Orientation of the wire end ferrules

- The orientation of the wire end ferrule in the clamping point has to be vertical.

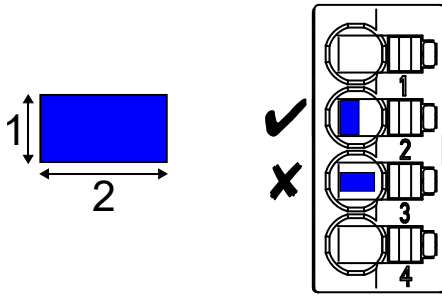

Fig. 8: Orientation of the wire end ferrules in the clamping point

- 1 Height of the crimped wire end ferrule
- 2 Width of the crimped wire end ferrule

### 8.6.6 Mounting strands

- Press the pusher with a suitable slotted screwdriver.
- Insert the strand into the terminal point as far as possible.
- Release the pusher.

### 8.6.7 Unmounting strands

- Press the pusher with a suitable slotted screwdriver.
- Remove strands.
- Release the pusher.

### 8.6.8 Mounting notes for UL certification

#### Permitted strands

- Use a braid with wire end ferrules for UL devices.
- The following wire end ferrules are permitted:
  - Wire end ferrules with insulating collar as per the table:

Cable cross-section in AWG	Cable cross-section mm <sup>2</sup>	Ordering numbers of the wire end ferrules (Weidmüller company)
24 AWG	0.2 mm <sup>2</sup>	9025760000, 500 pieces
22 AWG	0.35 mm <sup>2</sup>	9025770000, 500 pieces
20 AWG	0.5 mm <sup>2</sup>	0690700000, 500 pieces 1476230000, 100 pieces
18 AWG	0.75 mm <sup>2</sup>	0462900000, 500 pieces 1476240000, 100 pieces
-	1 mm <sup>2</sup>	0463000000, 500 pieces 1476250000, 100 pieces
16 AWG	1.5 mm <sup>2</sup>	0463100000, 500 pieces 1476270000, 100 pieces

#### Strand orientation

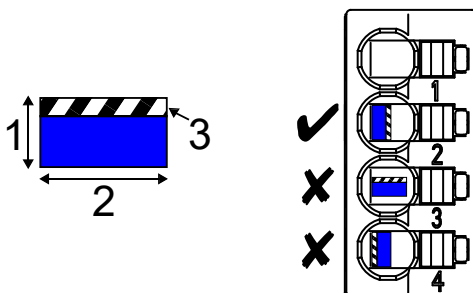

Fig. 9: Orientation of the wire end ferrules in the clamping point

- 1 Height of the crimped wire end ferrule
- 2 Width of the crimped wire end ferrule
- 3 Crimped side of the wire end ferrule

## 8.7 Removing plug

1. Press the locking lever of the plug at the top, see ①
2. Remove the plug, see ②.

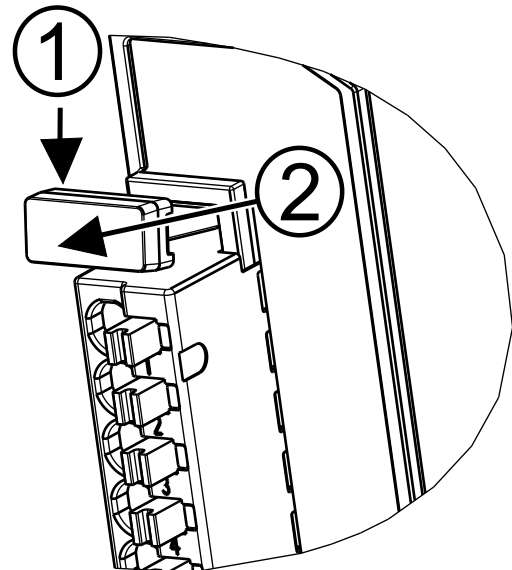

Fig. 10: Removing plug

## 8.8 Dismounting module

⚠ For dismounting, use a common tool such as a slotted screwdriver with a 2.5 mm blade.

#### NOTICE

#### Destruction of components and devices due to mounting and dismounting under voltage!

Disconnect the module and all connected module components from voltage before mounting or dismounting.

#### Removing module from support rail

1. Use a suitable tool (e.g. slotted screwdriver) and put it into the lower disengaging mechanism (base latch) of the module and disengage the module (see (A) in the following figure). The base latch is locked in the open position.
2. Remove the module vertically to the support rail [see (B) in the following figure].

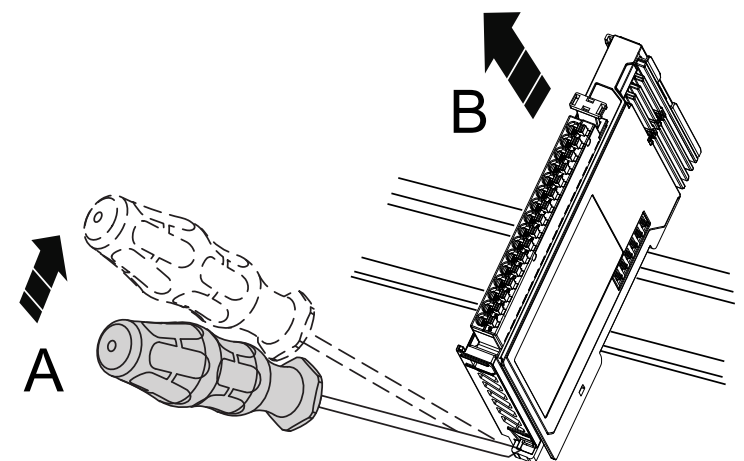



Fig. 11: Removing module from support rail

⚠ Before mounting the module on the support rail again, release the clamping of the open position again. Press the locking lever, refer to the figure 5.

## 9 License information

### 9.1 EtherCAT®

**EtherCAT** Technology Group  The ctrlX I/O modules use EtherCAT® technology. "EtherCAT®" is a registered trademark and patented technology licensed by the Beckhoff Automation GmbH, Germany. EtherCAT is an open, internationally standardized standard and developed further by the "EtherCAT Technology Group" (ETG).

Bosch Rexroth AG  
Bgm.-Dr.-Nebel-Str. 2  
97816 Lohr a.Main  
Germany  
Tel. +49 9352 18 0  
Fax +49 9352 18 8400  
[www.boschrexroth.com/electrics](http://www.boschrexroth.com/electrics)



DC-AE/EPI5 (AnBe/MaKo/MePe)